

Four-row linear recirculating ball bearing and guideway assemblies

Guideway with teeth on underside or toothed rack with lateral teeth



New!
Lateral gear teeth

For driven guideways, the four-row linear recirculating ball bearing and guideway assemblies KUVE..B ZHP have been available for some time. In these series, the guideways have right hand helical teeth with a mesh angle of 20° . The teeth are aligned downwards, hardened and ground. In comparison with units without teeth, these designs are more precise, allow significantly simpler adjacent constructions and give considerable reductions in fitting and logistical requirements.

In order to increase further the potential applications of toothed guideways, the proven range has been expanded to include the series KUVE..B ZHST SVS. These units have a combination of a standard guideway TKVD with a toothed rack ZHST..SVS. Furthermore, the hardened and ground helical teeth are arranged laterally. This gives even more flexible fitting possibilities and increased free space in the design of the adjacent construction.

Due to their modular design, the toothed series are suitable for all carriage types (except the wide W designs) and thus can be simply converted.

The rolling element system of the guidance systems is lubricated by grease or oil. The teeth can be easily lubricated by means of felt gears and electronically controlled lubricators.

The guidance systems can be used across a wide range of temperatures and are most suitable for applications in the handling equipment and automation technology sectors.

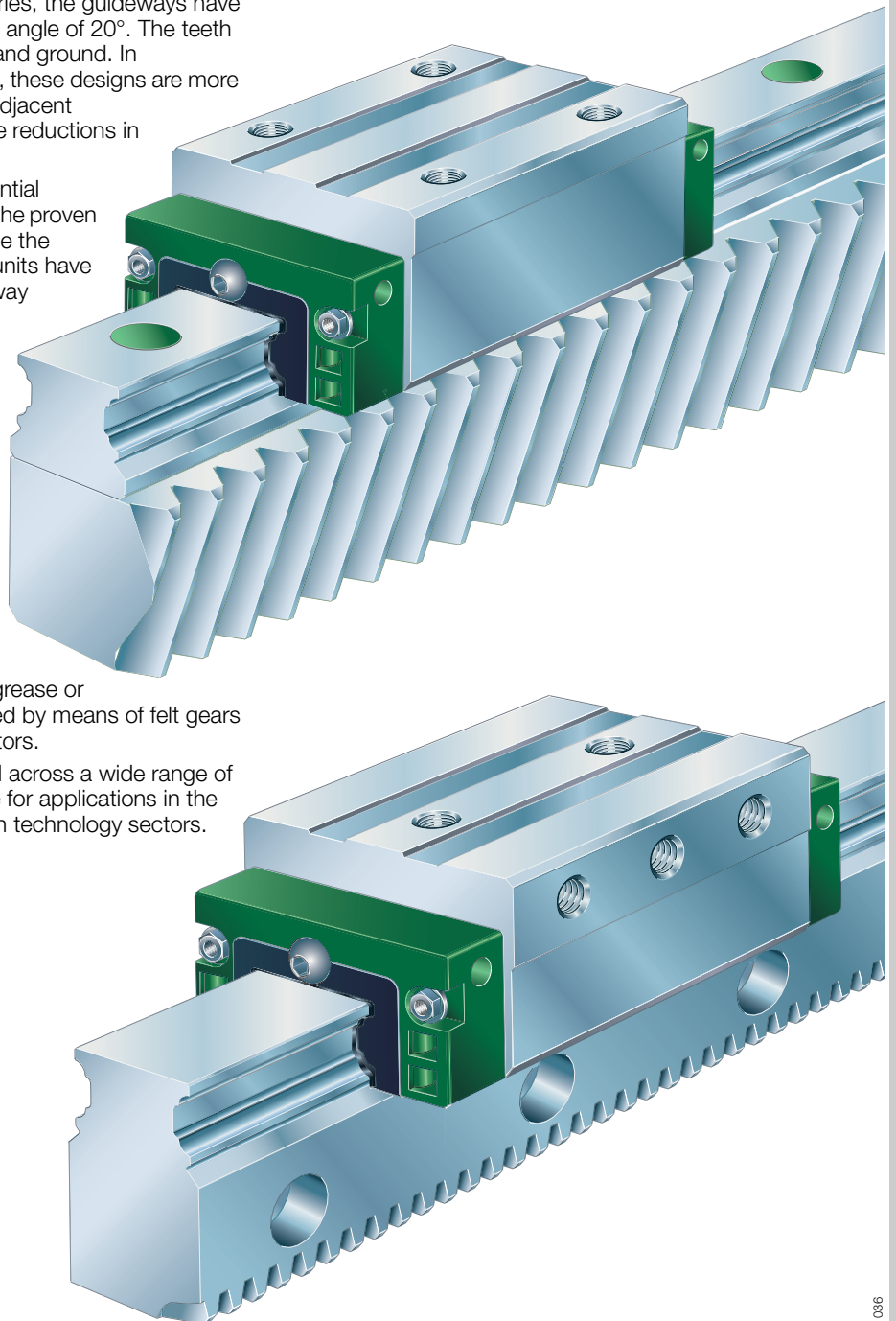

205 036

Four-row linear recirculating ball bearing and guideway assemblies

Guideway with teeth on underside



Ordering example and ordering designation 3



Design and safety guidelines 10



Accessories 10



Features

Four-row linear recirculating ball bearing and guideway assemblies

- of these series are complete units comprising:
 - a carriage KWVE..B or KWVE..B KT
 - a guideway TKVD..ZHP with helical gear teeth on the underside
- expand on the advantages of units without teeth through:
 - considerably reduced fitting work
 - increased accuracy
 - simplified design and machining of the adjacent construction
 - reduced logistical work
- are available in sizes 25 and 35
- are of a modular concept, i. e.:
 - within one size, toothed guidance units can be combined with all carriage types (exception: wide W designs)
- can support forces from all directions and moments about all axes
- are preloaded
- have high load carrying capacity and rigidity
- can also be supplied as a preassembled unit for higher accuracies
- have integral elastic wipers on the end faces of the carriage and sealing strips for sealing the carriage
- can be lubricated with oil or grease
 - the rolling contact is relubricated by means of a lubrication connector in the end piece of the carriage
 - the teeth must be lubricated separately. For example, a felt gear and electronically controlled lubricator can be used
- are suitable for temperatures from -10 °C to $+100\text{ °C}$
- are highly suitable for applications
 - in the handling equipment and automation technology sectors.



Further information on the linear recirculating ball bearing and guideway assemblies:
 INA Catalogue "Monorail guidance systems" 605
 and "MAI 91", INA-CD-ROM "medias® professional"

Toothed guideway with SB carriage



KUVE..B SB ZHP

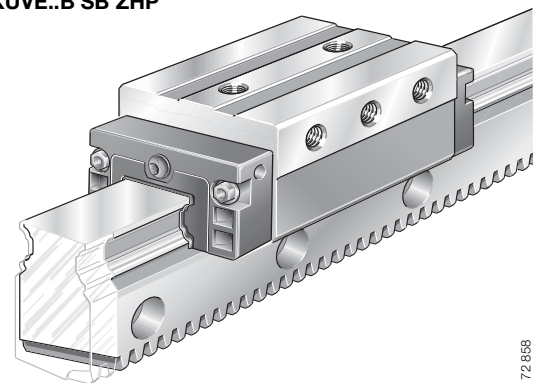

172 858

- carriage KWVE..B SB with lateral fixing holes
- guideway TKVD..ZHP with helical gear teeth on the underside
 - tooth grade 6, right hand helical teeth $19^{\circ} 31' 42''$, hardened and ground, mesh angle 20°



Toothed guideway with H carriage



KUVE..B H ZHP

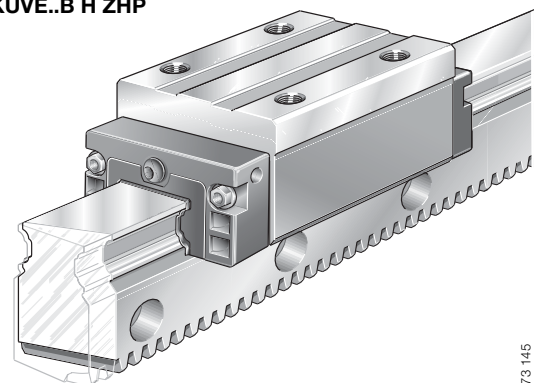

173 145

- carriage KWVE..B H with fixing holes for screw mounting from above
- guideway TKVD..ZHP with helical gear teeth on the underside
 - tooth grade 6, right hand helical teeth $19^{\circ} 31' 42''$, hardened and ground, mesh angle 20°



Ordering example and ordering designation

Standard manufacturing lengths: see page 4, footnotes 4)5).

Guideway identical to standard manufacturing length; start and end of guideway cut obliquely

Four-row linear ball bearing and guideway	KUVE..B
Size	25
Carriage for screw mounting from side	SB
Guideway with teeth on underside	ZHP
Number of carriages per unit	W2
Carriage preload	V2
Guideway length	1500 mm

Ordering designation:

KUVE 25 B SB ZHP W2 V2/1500 (Figure 1).



Even with $n \times l_{\max}$, the individual sections of the guideways have obliquely cut ends.

Guideway smaller than standard manufacturing length; start and end of guideway cut obliquely

Four-row linear ball bearing and guideway	KUVE..B
Size	35
Narrow carriage	S
Guideway with teeth on underside	ZHP
Number of carriages per unit	W1
Carriage preload	V1
Guideway length	1400 mm

Ordering designation:

KUVE 35 B S ZHP W1 V1/1400 (Figure 2).

Guideway larger than standard manufacturing length; start and end of guideway cut straight, joints in guideways cut obliquely

Four-row linear ball bearing and guideway	KUVE..B
Size	25
High carriage	H
Guideway with teeth on underside	ZHP
Number of carriages per unit	W2
Carriage preload	V2
Guideway length	2700 mm

Ordering designation:

KUVE 25 B H ZHP W2 V2/2700 (Figure 3).

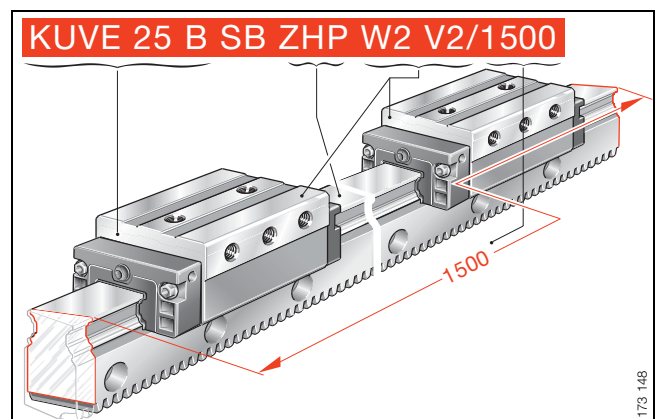

Figure 1 · Ordering example and ordering designation – ends of guideway oblique

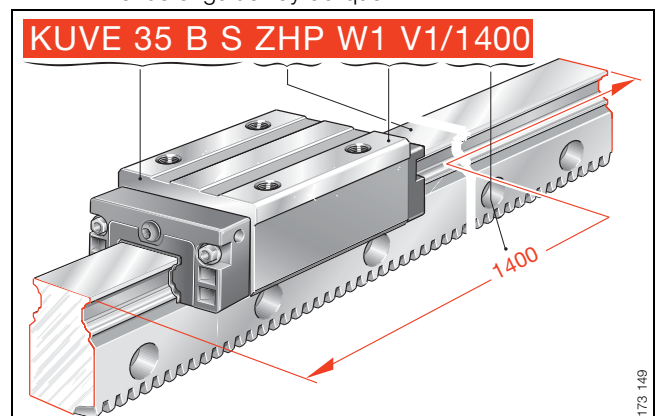

Figure 2 · Ordering example and ordering designation – ends of guideway straight

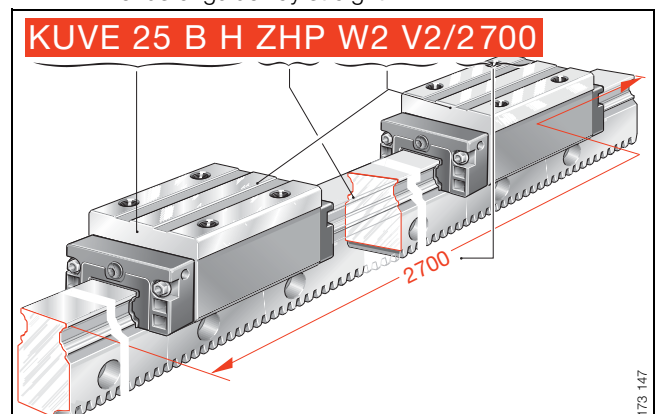
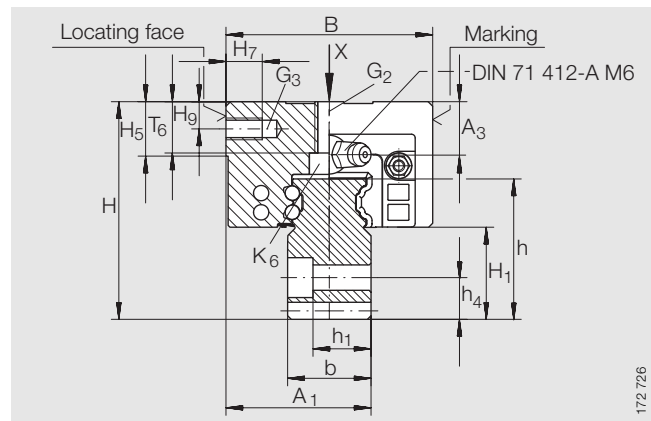

Figure 3 · Ordering example and ordering designation – joints in guideways oblique, ends straight

Four-row linear recirculating ball bearing and guideway assemblies

Guideway with teeth on underside

Series KUVE..B SB ZHP



KUVE..B SB ZHP

Dimension table · Dimensions in mm

Unit Designation	Carriage		Guideway		Mounting dimensions				Mounting dimensions		
	Designation	Mass ≈kg	Designation	Mass ≈kg/m	l_{max}	H	B	L	A_1	A_3	b -0,005 -0,03
KUVE 25 B SB ZHP⁷⁾	KWVE 25 B SB	0,85	TKVD 25 ZHP	6,3	1500 ¹⁾⁴⁾	60	57	81,7	40	15	23
KUVE 35 B SB ZHP⁷⁾	KWVE 35 B SB	1,8	TKVD 35 ZHP	14	1680 ¹⁾⁵⁾	85	76	110,4	55	19,3	34

1) Maximum length l_{max} of guideway; longer guideways are supplied in several sections and are marked accordingly.

2) a_L and a_R are dependent on the guideway length L.

3) If there is a possibility of settling, the fixing screws should be secured against rotation.

4) Toothed guideways of size 25 are manufactured in the following lengths: $l_{max} = 1500$ mm, 960 mm, 540 mm. The ends of guideways of these lengths are cut obliquely and can be used directly for joining of guideways.

5) Toothed guideways of size 35 are manufactured in the following lengths: $l_{max} = 1680$ mm, 1120 mm, 560 mm. The ends of guideways of these lengths are cut obliquely and can be used directly for joining of guideways.

6) See Figure *Load directions*.

7) Teeth, centre distance and ratio to DIN 3 975/76.

Screw diameters and tightening torques

Designation	Fixing screws ISO 4 762-12.9 ³⁾							
	K ₁		G ₂		G ₃		K ₆	
		M_A Nm		M_A Nm		M_A Nm		M_A Nm
KUVE 25 B SB ZHP	M6	17	M 8	24	M6	17	M6	17
KUVE 35 B SB ZHP	M8	41	M10	83	M8	41	M8	41

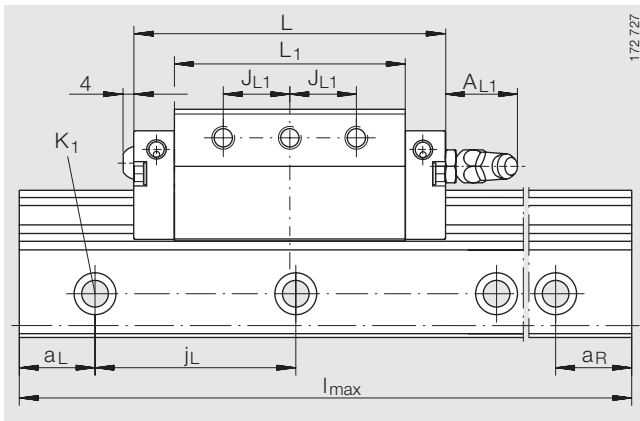

172 727

KUVE..B SB ZHP

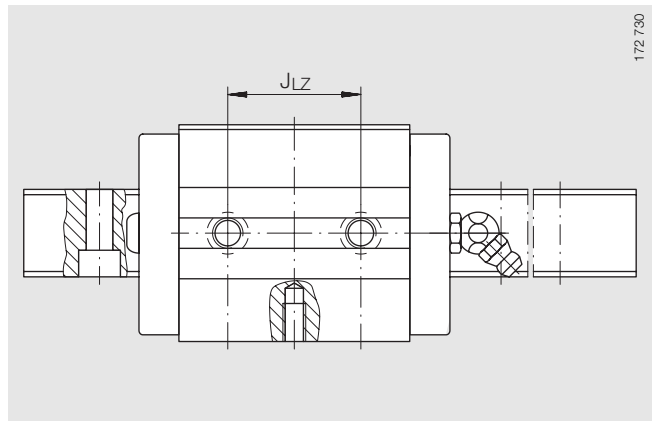

172 730

KUVE..B SB ZHP · View X (rotated 90°)

L ₁	J _{LZ}	j _L	a _L ²⁾		a _R ²⁾		A _{L1}	J _{L1}	H ₁	H ₅	T ₆	H ₇	H ₉	h	h ₁	h ₂	h ₄	Module m
			min.	max.	min.	max.												
60,7	35	60	20	53	20	53	19	17,5	25,2	15	14,8	10	7,5	38,7	13	3	11,5	2
80	50	80	20	71	20	71	19	25	36,8	22	18,15	13	11	57	22	5	17	3

Load carrying capacity

Designation	Basic load ratings		Moment ratings ⁶⁾		
	dyn. C kN	stat. C ₀ kN	M _{0x} Nm	M _{0y} Nm	M _{0z} Nm
KUVE 25 B SB ZHP	17,9	37	510	395	395
KUVE 35 B SB ZHP	38	72	1465	1020	1020

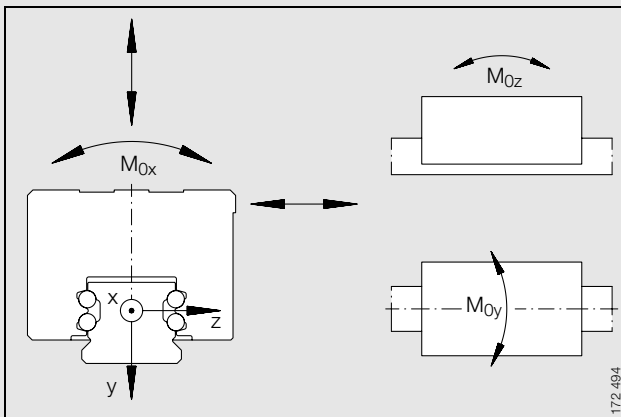

172 494

Load directions

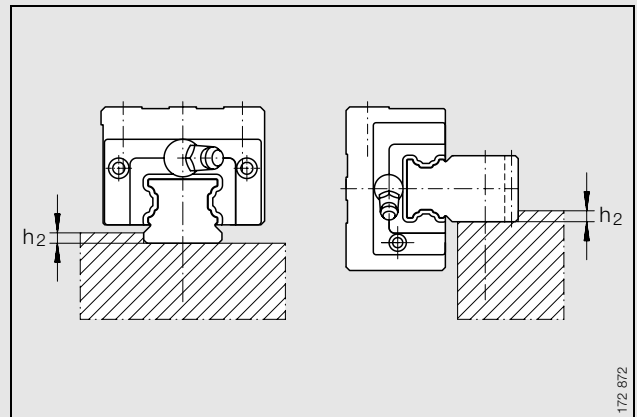

172 572

KUVE..B SB ZHP

Four-row linear recirculating ball bearing and guideway assemblies

Toothed rack with lateral teeth



Ordering example and ordering designation 7



Design and safety guidelines 10



Accessories 10



Features

Four-row linear recirculating ball bearing and guideway assemblies

- of these series are complete units comprising:
 - a carriage KWVE..B or KWVE..B KT
 - a guideway TKVD..ZHST
 - a toothed rack ZHST..SVS with lateral helical teeth
- expand on the advantages of units without teeth through:
 - increased fitting possibilities
 - interchangeability of individual elements
 - considerably reduced fitting work
 - reduced logistical work
- are available in sizes 25, 30 and 35
- are of a modular concept, i.e.:
 - within one size, toothed guidance units can be combined with all carriage types (exception: wide W designs)
- can support forces from all directions and moments about all axes
- are preloaded
- have high load carrying capacity and rigidity
- are supplied as a preassembled unit
- have integral elastic wipers on the end faces of the carriage and sealing strips for sealing the carriage
- can be lubricated with oil or grease
 - the rolling contact is relubricated by means of a lubrication connector in the end piece of the carriage
 - the teeth must be lubricated separately. For example, a felt gear and electronically controlled lubricator can be used
- are suitable for temperatures from -10 °C to $+100\text{ °C}$
- are highly suitable for applications
 - in the handling equipment and automation technology sectors.



Further information on the linear recirculating ball bearing and guideway assemblies:
 INA Catalogue "Monorail guidance systems" 605
 and "MAI 91", INA-CD-ROM "medias® professional"



KUVE..B N ZHST SVS

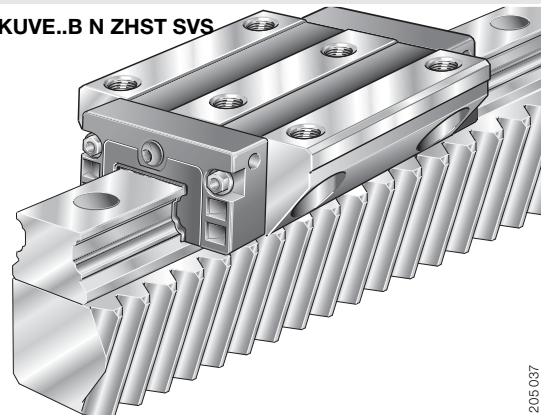

205 037

- carriage KWVE..B N with fixing holes for screw mounting from above
- guideway TKVD..ZHST SVS with lateral helical teeth
 - tooth grade 6, right hand helical gear teeth, $19^{\circ} 31' 42''$, hardened and ground, mesh angle 20°



8



KUVE..B ZHST SVS

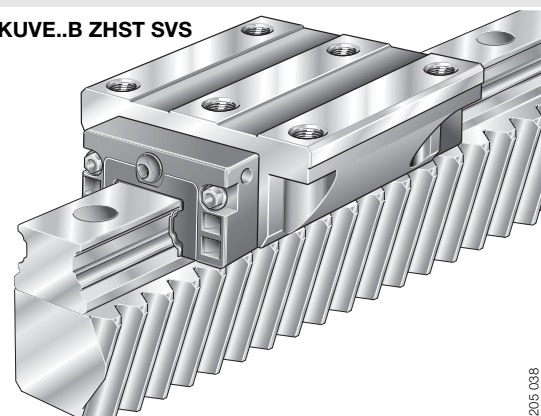

205 038

- carriage KWVE..B with fixing holes for screw mounting from above
- guideway TKVD..ZHST SVS with lateral helical teeth
 - tooth grade 6, right hand helical gear teeth, $19^{\circ} 31' 42''$, hardened and ground, mesh angle 20°



Ordering example and ordering designation

Standard manufacturing lengths: see page 8, footnotes ¹⁾.
Toothed racks are only supplied with guideways.

Unit

Four-row linear ball bearing and guideway assembly	KUVE..B
Size	25
Guideway with toothed rack with lateral helical teeth	TKVD 25 ZHST SVS
Number of carriages per unit	W1
Carriage preload	V1
Guideway length	900 mm

Ordering designation:
KUVE 25 B ZHST SVS W1 V1/900 (Figure 1).

Guideway with toothed rack

Guideway of size 25, toothed rack with lateral helical teeth	TKVD 25 ZHST SVS
Guideway length	2 860 mm

Ordering designation:
TKVD 25 ZHST SVS/2 860 (Figure 2).

Note

The guidance unit TKVD..ZHST SVS is supplied ready assembled.

For guideway lengths of more than 2 880 mm, the unit is supplied in subunits for joining for reasons of handling (the guideway and toothed rack are assembled). A mating piece is required for fitting and can be supplied on request. These fitting aids have left hand teeth.

By agreement, single-piece guideways are available up to 5 740 mm.

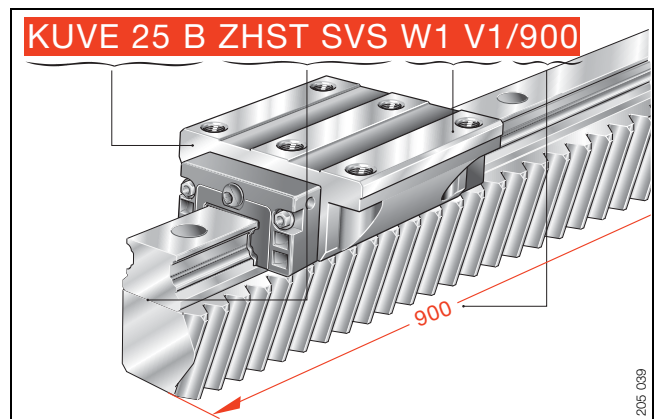

Figure 1 · Ordering example and ordering designation – unit

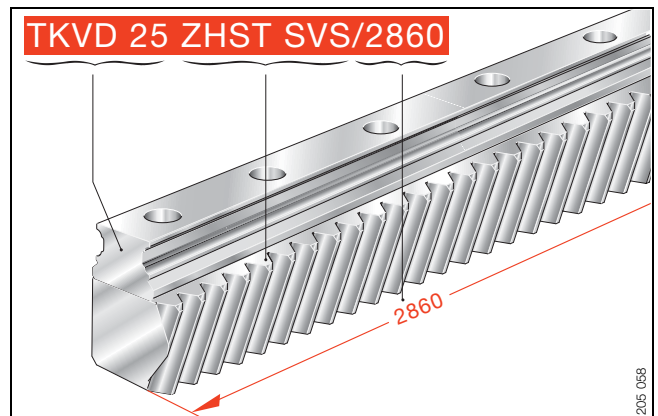

Figure 2 · Ordering example and ordering designation – guideway with toothed rack

Four-row linear recirculating ball bearing and guideway assemblies

Toothed rack with lateral teeth

Series KUVE..B ZHST SVS

Dimension table · Dimensions in mm											
Unit Designation	Carriage		Guideway		Mounting dimensions				Mounting dimensions		
	Designation	Mass ≈kg	Designation	Mass ≈kg/m	$l_{\max}^{1)}$	H	B	L	A_1	A_3	b -0,005 -0,03
KUVE 25 B ZHST SVS³⁾	KWVE 25 B	0,71	TKVD 25 ZHST SVS	8,5	2 860	65	70	81,7	23,5	11	29,75
KUVE 30 B ZHST SVS³⁾	KWVE 30 B	1,4	TKVD 30 ZHST SVS	15	2 860	81	90	97,6	31	11,25	39,75
KUVE 35 B ZHST SVS³⁾	KWVE 35 B	2,02	TKVD 35 ZHST SVS	19,2	2 860	87	100	110	33	12,3	48,75

- 1) The maximum single-piece length of the toothed rack is 960 mm.
The maximum single-piece selling length of the toothed rack is 2 860 mm.
By agreement, it may be possible to obtain a single-piece unit up to 5 740 mm.
- 2) a_L and a_R are dependent on the guideway length.
- 3) Teeth, centre distance and ratio to DIN 3 975/76.
- 4) If there is a possibility of settling, the fixing screws should be secured against rotation.
- 5) See Figure *Load directions*.

Screw diameters and tightening torques

Designation	Fixing screws ISO 4 762-12.9 ⁴⁾							
	K ₁		G ₂		K ₃		K ₆	
		M_A Nm		M_A Nm		M_A Nm		M_A Nm
KUVE 25 B ZHST SVS	M6	17	M 8	24	M6	17	M6	17
KUVE 30 B ZHST SVS	M8	41	M10	41	M8	41	M8	41
KUVE 35 B ZHST SVS	M8	41	M10	41	M8	41	M8	41

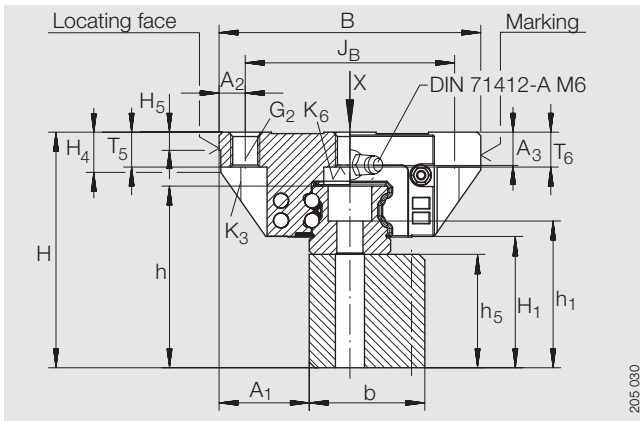

KUVE..B ZHST SVS

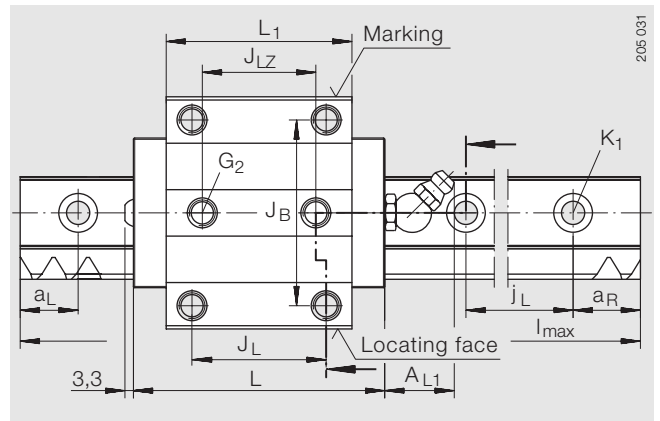

KUVE..B ZHST SVS · View X (rotated through 90°)

h ₅	L ₁	J _B	J _{LZ}	j _L	a _L ²⁾		a _R ²⁾		A _{L1}	A ₂	J _L	H ₁	H ₄	H ₅	T ₅	T ₆	h	h ₁	Module m
					min.	max.	min.	max.											
29	60,7	57	40	60	28	32	8	32	19	6,5	45	34,4	10,9	5	10	10	47,7	37,7	3
39	72	72	44	80	28	51	8	51	19	9	52	45	13,8	6	12	12	62,5	50,5	4
39	80	82	52	80	28	51	8	51	19	9	62	45,8	14,3	6,5	13	12	66	54	4

Load carrying capacity

Designation	Basic load ratings		Moment ratings ⁵⁾		
	dyn. C kN	stat. C ₀ kN	M _{0x} Nm	M _{0y} Nm	M _{0z} Nm
KUVE 25 B ZHST SVS	17,9	37	510	395	395
KUVE 30 B ZHST SVS	27,5	55	970	700	700
KUVE 35 B ZHST SVS	38	72	1465	1020	1020

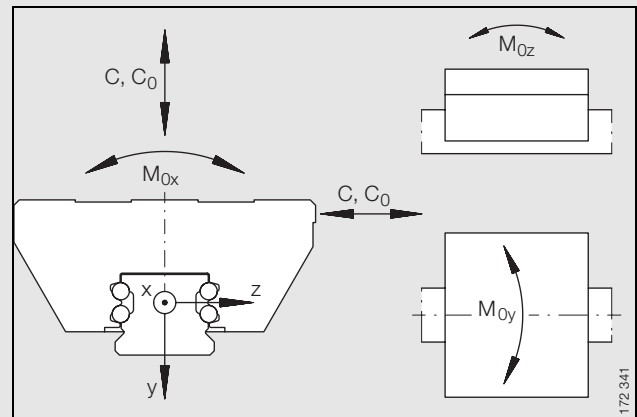

Load directions

Four-row linear recirculating ball bearing and guideway assemblies

Guideway with teeth on underside
or toothed rack with lateral teeth



Design and safety guidelines

Permissible torques for toothed racks

For flank and tooth fracture loading with good grease lubrication (i. e. use of electronic lubricators or adequate manual lubrication once per day) and $v = 1,5 \text{ m/s}$, $S_B = 1,0$ together with a unilateral stable bearing arrangement for the pinion shaft, the torques in Table 1 to 3 apply. If a feather key connection is used, this torque must if necessary be calculated separately or checked in accordance with DIN 6 885-1.

Permissible torques with shrink fit washer:
see *dimension table* Accessories.

Fitting aids for guideways of any length

In order to facilitate fitting of guideways TKVD..ZHP and TKVD..ZHST SVS of any length, mating pieces are available on request for fitting. These fitting aids have teeth running in the opposite direction.

Safety specifications



The following protective measures must be observed in all cases:

Do not touch rotating parts – e.g. input and output shaft, spur gear, toothed rack etc.

Do not undo the screw plugs on the gearbox.

Avoid direct contact with lubricants.

Pay attention to the datasheets from the lubricant and gearbox manufacturers.

In the case of toothed racks ZHP and ZHST SVS with ends cut straight, there is a risk of injury due to sharp edges.



Accessories

Gearbox

- High performance worm gear pair, specially intended for the new generation of three-phase current and direct-current servomotors
- Light metal housing for optimum heat dissipation
- Smooth running
- Installation in any position
- Ratios: $i = 4,75; 6,75; 9,25; 14,5; 19,5; 29, 39, 50$
- Low backlash tooth set (backlash < 2 , adjustable)
- 5 machined locating surfaces with adequately dimensioned fixing and threaded holes for stress-free mounting in all installation positions.

Table 1 · Guideway ZHP, toothed rack of module 2

Number of teeth on pinion ¹⁾	Hardened teeth Max. torque Nm
28	250
30	270
32	290

Table 2 · Guideway ZHP and toothed rack ZHST of module 3

Number of teeth on pinion ¹⁾	Hardened teeth Max. torque Nm	
	ZHP	ZHST
20	505	410
22	530	430
25	605	490
30	720	550

Table 3 · Toothed rack ZHST of module 4

Number of teeth on pinion ¹⁾	Hardened teeth Max. torque Nm
15	670
21	1020
24	1150

¹⁾ Hardened pinion.

Mounting position

If the additional forces are to be fully utilised, the gearbox should be flange mounted on the largest locating surfaces.

The most favourable mounting position for lubrication is achieved with a lateral or bottom-mounted worm shaft.



With a top-mounted worm shaft, the drive power is reduced by approx. 10%.

Flank backlash

The flank backlash is set to the smallest possible value at the manufacturing plant. If the backlash changes after a long period of operation, it can be corrected to the specified value by means of the eccentrically supported input shaft.

Lubrication

The gearboxes are filled with synthetic lubricant. The filling should be checked monthly and several times in the first weeks of operation.



Under moderate load, the lubricant should be changed between once and four times per year (for single, double or triple shift operation).

Coupling

- Bore on the gearbox side; backlash-free tooth hub profile for push mounting – similar to DIN 5 480 (Figure 1, A)
- Bore on the motor side with annular spring elements as clamping connection (Figure 1, B)
- Preassembled.

Before fixing on the motor shaft as contact surfaces, clean and protect using a light oil film – this prevents fretting corrosion.

Input shafts

- Helical teeth, $19^{\circ} 31' 42''$, mesh angle 20°
- Ground teeth, grade 6 e 25 – similar to DIN 3 962/63/67
- Case hardened.

Before assembly, clean input shafts and lightly grease or oil – this prevents fretting corrosion.

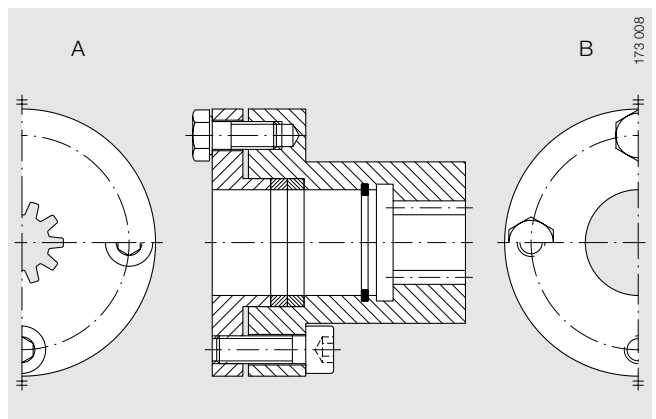
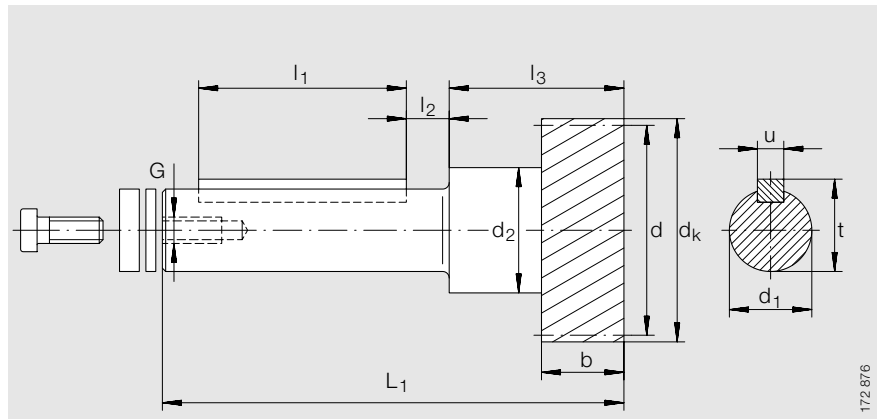

Figure 1 · Coupling

Accessories

Input shafts
Coupling
Clamping connections



Input shaft for feather key connection

Input shaft, helical teeth · Dimensions in mm

Ordering designation	Mass ≈kg	Distance between axes	Module	Number of teeth	Dimensions											
					d	dk	b	d _{1 i6}	d ₂	L ₁	l ₁	l ₂	l ₃	u	t	G
RITZ 02 30 50 PF¹⁾	1,25	50	2	30	63,66	67,7	25	25	38	140	63	13	53	8	28	M8
RITZ 02 30 63 PF¹⁾	1,5	63	2	30	63,66	67,7	25	28	42	164,5	80	14,5	57,5	8	31	M8
RITZ 02 30 50 PF²⁾	1,25	50	2	30	63,66	67,7	25	25	38	140	–	–	34	–	–	–
RITZ 02 30 63 KL²⁾	1,6	63	2	30	63,66	67,7	25	28	42	164,5	–	–	38,5	–	–	–
RITZ 03 20 50 PF¹⁾	1,33	50	3	20	63,66	69,7	30	25	38	142	63	13	55	8	28	M8
RITZ 03 20 63 PF¹⁾	1,6	63	3	20	63,66	69,7	30	28	42	167	80	14,5	60	8	31	M8
RITZ 03 20 50 KL²⁾	1,33	50	3	20	63,66	69,7	30	25	38	142	–	–	36,5	–	–	–
RITZ 03 20 63 KL²⁾	1,6	63	3	20	63,66	69,7	30	28	42	167	–	–	41	–	–	–
RITZ 04 15 63 PF	1,85	63	4	15	63,66	71,7	40	28	42	172	80	14,5	65	8	31	M8
RITZ 04 16 63 KL	1,85	63	4	15	63,66	71,7	40	28	42	172	–	–	46	–	–	–

1) Input shaft for feather key connection.

2) Input shaft for shrink fit washer connection.

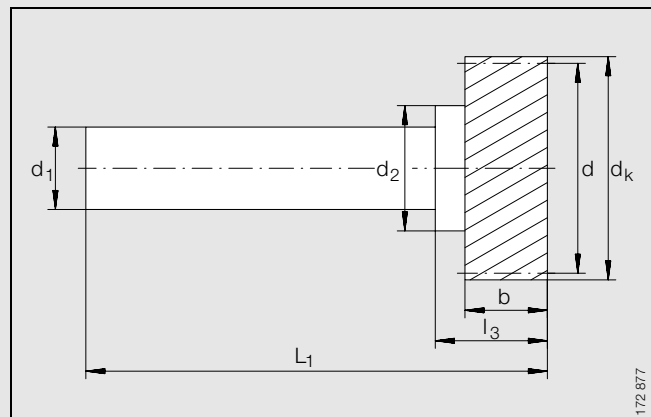

Input shaft for shrink fit washer connection

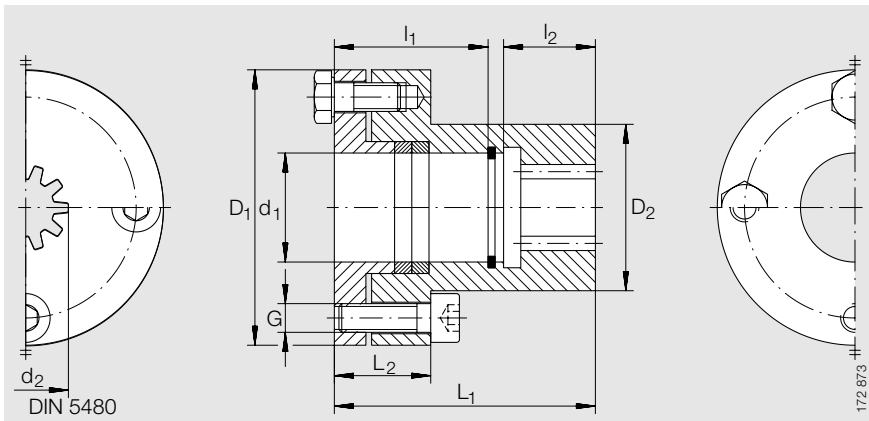

Coupling

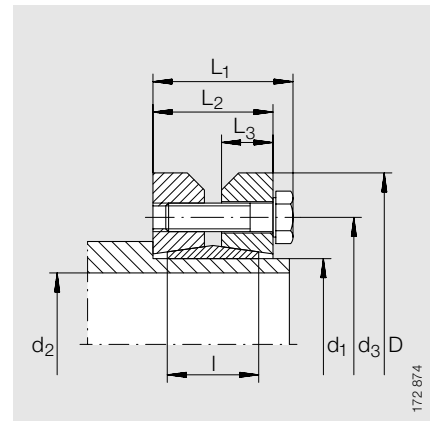

Clamping connection

Coupling · Dimensions in mm

Ordering designation	Mass ≈kg	J _{red} 10 ⁻⁴ kg/m ²	Dimensions										G	
			d ₁	d ₂	D ₁	D ₂	l ₁	l ₂	l ₄	L ₁	L ₂	Quantity	Tightening torque M _A Nm	
KUP 65 43 119	0,4	0,799	19	15×1,25×10	48	29	24	16	5	40	18	4×M5	7	

Clamping connection · Dimensions in mm

Ordering designation	Mass ≈kg	J _{red} 10 ⁻⁴ kg/m ²	Dimensions									G	
			a ₀	d ₁	d ₂	d ₃	D	L ₁	L ₂	L ₃	l	Quantity	Tightening torque M _A Nm
SPE 80 83 030	0,3	1,756	50	30	25	44	60	25	21,5	9	16	7×M5	4
SPE 80 84 036	0,4	4,029	63	36	28	52	72	27,5	23,5	10	18	5×M6	12

Accessories

Gearboxes

Gearbox · Dimensions in mm

Ordering designation		Mass ≈kg	J_{red} $10^{-4}kg/m^2$	Ratio i	Dimensions							
Input shaft with feather key connection	Input shaft with clamping connection				D^{G7}	k	r	x	y	f_1	e	G
GETR 50 SCHN 95 115 PF-5	GETR 50 SCHN 95 115 KL-5	7	0,483	4,75	95	222	152	5	42	100	115	M8

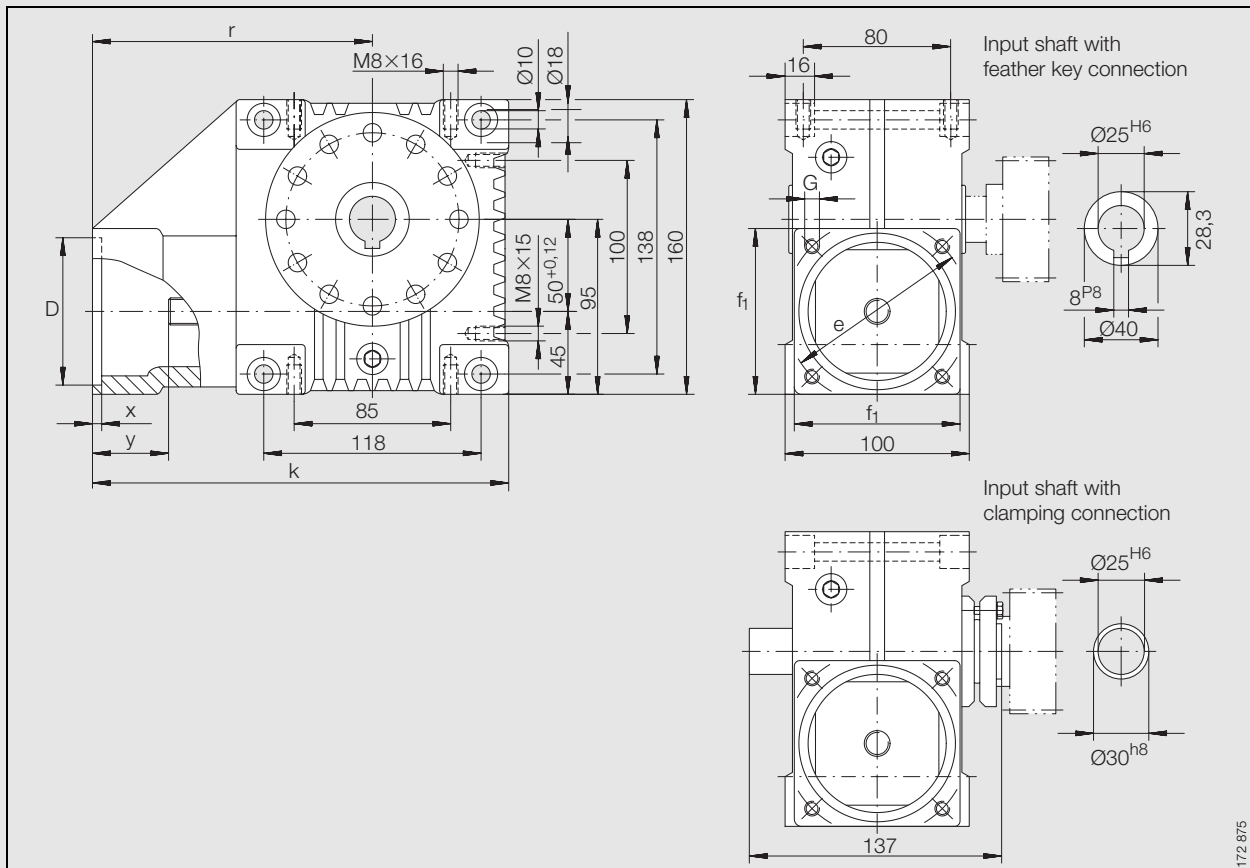

17.2.87/5

Gearbox · Dimensions in mm

Ordering designation		Mass ≈kg	J_{red} $10^{-4}kg/m^2$	Ratio i	Dimensions							
Input shaft with feather key connection	Input shaft with clamping connection				D ^{G7}	k	r	x	y	f ₁	e	G
GETR 63 SCHN 130 165 PF-39	GETR 63 SCHN 130 165 KL-39	12	1,01	39	95	265	180	5	48	100	115	M8

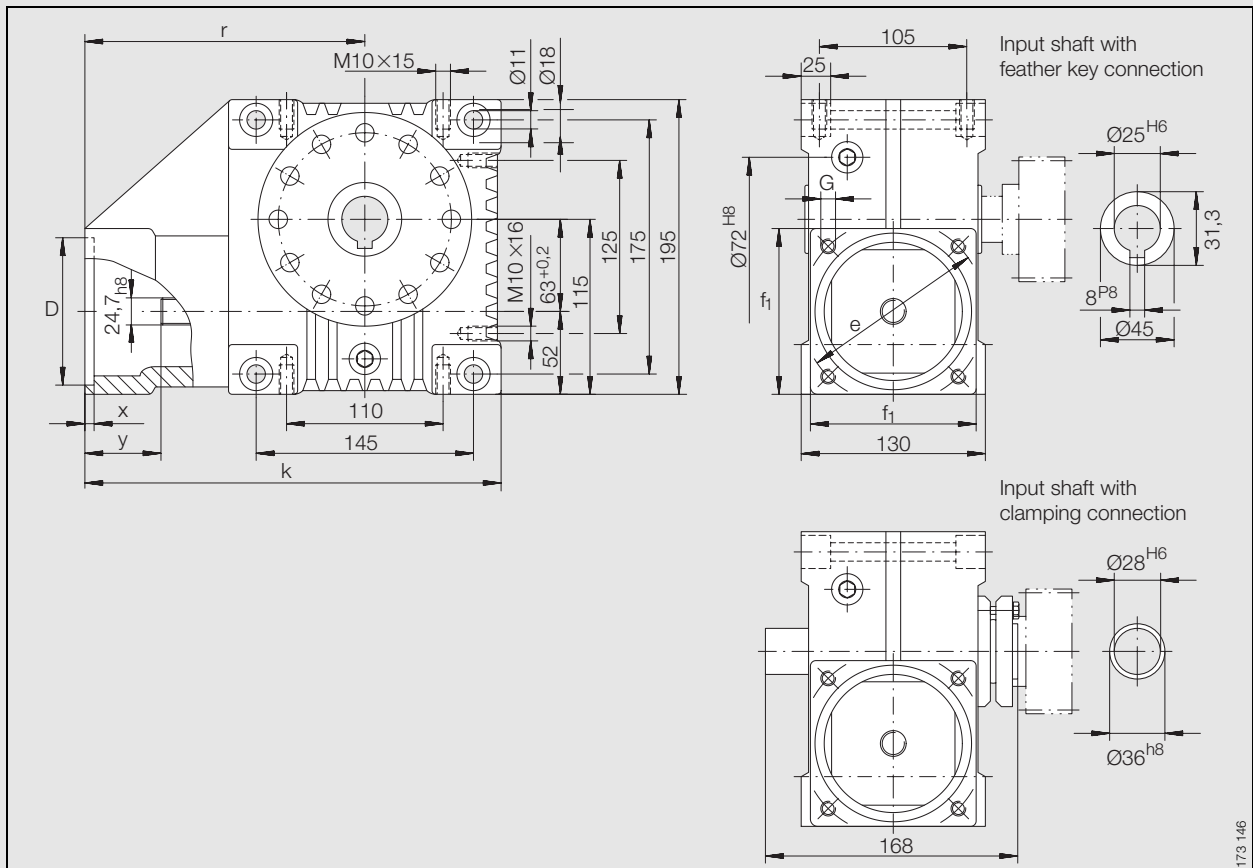

Gearbox with centre distance $a_0 = 63$ mm

Gearboxes

Centre distance $a_0 = 50$ mm

Gearbox, motor, pinion, coupling

Ordering designation		Motor	Pinion	Coupling
Atlanta	INA			
58 43 105	GETR 50 SCHN 95/115 PF-5	MOT HDX 115 ... ¹⁾	RITZ 023050 PF	KUP
58 43 107	GETR 50 SCHN 95/115 PF-7	MOT HDX 115 ... ¹⁾	RITZ 023050 PF	KUP
58 43 109	GETR 50 SCHN 95/115 PF-9	MOT HDX 115 ... ¹⁾	RITZ 023050 PF	KUP
58 43 115	GETR 50 SCHN 95/115 PF-15	MOT HDX 115 ... ¹⁾	RITZ 023050 PF	KUP
58 43 120	GETR 50 SCHN 95/115 PF-20	MOT HDX 115 ... ¹⁾	RITZ 023050 PF	KUP
58 43 139	GETR 50 SCHN 95/115 PF-39	MOT HDX 115 ... ¹⁾	RITZ 023050 PF	KUP
58 43 150	GETR 50 SCHN 95/115 PF-50	MOT HDX 115 ... ¹⁾	RITZ 023050 PF	KUP
58 83 105	GETR 50 SCHN 95/115 KL-5	MOT HDX 115 ... ¹⁾	RITZ 023050 KL	KUP
58 83 107	GETR 50 SCHN 95/115 KL-7	MOT HDX 115 ... ¹⁾	RITZ 023050 KL	KUP
58 83 109	GETR 50 SCHN 95/115 KL-9	MOT HDX 115 ... ¹⁾	RITZ 023050 KL	KUP
58 83 115	GETR 50 SCHN 95/115 KL-15	MOT HDX 115 ... ¹⁾	RITZ 023050 KL	KUP
58 83 120	GETR 50 SCHN 95/115 KL-20	MOT HDX 115 ... ¹⁾	RITZ 023050 KL	KUP
58 83 139	GETR 50 SCHN 95/115 KL-39	MOT HDX 115 ... ¹⁾	RITZ 023050 KL	KUP
58 43 305	GETR 50 SCHN 80/100 PF-5	MOT HDX 92 E4-44 S	RITZ 023050 PF	KUP
58 43 307	GETR 50 SCHN 80/100 PF-7	MOT HDX 92 E4-44 S	RITZ 023050 PF	KUP
58 43 309	GETR 50 SCHN 80/100 PF-9	MOT HDX 92 E4-44 S	RITZ 023050 PF	KUP
58 43 315	GETR 50 SCHN 80/100 PF-15	MOT HDX 92 E4-44 S	RITZ 023050 PF	KUP
58 43 320	GETR 50 SCHN 80/100 PF-20	MOT HDX 92 E4-44 S	RITZ 023050 PF	KUP
58 43 339	GETR 50 SCHN 80/100 PF-39	MOT HDX 92 E4-44 S	RITZ 023050 PF	KUP
58 43 350	GETR 50 SCHN 80/100 PF-50	MOT HDX 92 E4-44 S	RITZ 023050 PF	KUP
58 83 305	GETR 50 SCHN 80/100 KL-5	MOT HDX 92 E4-44 S	RITZ 023050 KL	KUP
58 83 307	GETR 50 SCHN 80/100 KL-7	MOT HDX 92 E4-44 S	RITZ 023050 KL	KUP
58 83 309	GETR 50 SCHN 80/100 KL-9	MOT HDX 92 E4-44 S	RITZ 023050 KL	KUP
58 83 315	GETR 50 SCHN 80/100 KL-15	MOT HDX 92 E4-44 S	RITZ 023050 KL	KUP
58 83 320	GETR 50 SCHN 80/100 KL-20	MOT HDX 92 E4-44 S	RITZ 023050 KL	KUP
58 83 339	GETR 50 SCHN 80/100 KL-39	MOT HDX 92 E4-44 S	RITZ 023050 KL	KUP

¹⁾ MOT HDX 115 A6-64 S or MOT HDX 115 C6-88 S.
Information on motors and controls: see *INA publication "ALE"*.
Other designs available by agreement.

Gearboxes

Centre distance $a_0 = 63 \text{ mm}$

Gearbox, motor, pinion, coupling

Ordering designation		Motor	Pinion	Coupling
Atlanta	INA			
58 44 105	GETR 63 SCHN 95/115 PF-5	MOT HDX 115 ... ¹⁾	RITZ 023063 PF	KUP
58 44 107	GETR 63 SCHN 95/115 PF-7	MOT HDX 115 ... ¹⁾	RITZ 023063 PF	KUP
58 44 109	GETR 63 SCHN 95/115 PF-9	MOT HDX 115 ... ¹⁾	RITZ 023063 PF	KUP
58 44 115	GETR 63 SCHN 95/115 PF-15	MOT HDX 115 ... ¹⁾	RITZ 023063 PF	KUP
58 44 120	GETR 63 SCHN 95/115 PF-20	MOT HDX 115 ... ¹⁾	RITZ 023063 PF	KUP
58 44 139	GETR 63 SCHN 95/115 PF-39	MOT HDX 115 ... ¹⁾	RITZ 023063 PF	KUP
58 84 105	GETR 63 SCHN 95/115 KL-5	MOT HDX 115 ... ¹⁾	RITZ 023063 KL	KUP
58 84 107	GETR 63 SCHN 95/115 KL-7	MOT HDX 115 ... ¹⁾	RITZ 023063 KL	KUP
58 84 109	GETR 63 SCHN 95/115 KL-9	MOT HDX 115 ... ¹⁾	RITZ 023063 KL	KUP
58 84 115	GETR 63 SCHN 95/115 KL-15	MOT HDX 115 ... ¹⁾	RITZ 023063 KL	KUP
58 84 120	GETR 63 SCHN 95/115 KL-20	MOT HDX 115 ... ¹⁾	RITZ 023063 KL	KUP
58 84 139	GETR 63 SCHN 95/115 KL-39	MOT HDX 115 ... ¹⁾	RITZ 023063 KL	KUP
58 44 205	GETR 63 SCHN 130/165 PF-5	MOT HDX 142 C6-88 S	RITZ 023063 PF	KUP
58 44 207	GETR 63 SCHN 130/165 PF-7	MOT HDX 142 C6-88 S	RITZ 023063 PF	KUP
58 44 209	GETR 63 SCHN 130/165 PF-9	MOT HDX 142 C6-88 S	RITZ 023063 PF	KUP
58 44 215	GETR 63 SCHN 130/165 PF-15	MOT HDX 142 C6-88 S	RITZ 023063 PF	KUP
58 44 220	GETR 63 SCHN 130/165 PF-20	MOT HDX 142 C6-88 S	RITZ 023063 PF	KUP
58 44 239	GETR 63 SCHN 130/165 PF-39	MOT HDX 142 C6-88 S	RITZ 023063 PF	KUP
58 84 205	GETR 63 SCHN 130/165 KL-5	MOT HDX 142 C6-88 S	RITZ 023063 KL	KUP
58 84 207	GETR 63 SCHN 130/165 KL-7	MOT HDX 142 C6-88 S	RITZ 023063 KL	KUP
58 84 209	GETR 63 SCHN 130/165 KL-9	MOT HDX 142 C6-88 S	RITZ 023063 KL	KUP
58 84 215	GETR 63 SCHN 130/165 KL-15	MOT HDX 142 C6-88 S	RITZ 023063 KL	KUP
58 84 220	GETR 63 SCHN 130/165 KL-20	MOT HDX 142 C6-88 S	RITZ 023063 KL	KUP

¹⁾ MOT HDX 115 A6-64 S or MOT HDX 115 C6-88 S.
 Information on motors and controls: see *INA publication "ALE"*.
 Other designs available by agreement.



INA-Schaeffler KG

Linear Technology Division
66406 Homburg (Saar) · Germany

Internet www.ina.com

E-Mail info.linear@de.ina.com

In Germany:

Telephone 0180/5 00 38 72

Fax 0180/5 00 38 73

From other countries:

Telephone +49/68 41/7 01-0

Fax +49/68 41/7 01-6 25