

Accurate, versatile
chemical pumps





- Cut chemical cost through higher accuracy metering
- Simple drop-in installation eliminates ancillary equipment
- Reduced maintenance with single, no-tools, component replacement
- Range expanded to include Qdos 60. Flow rates from 0.1 to 1,000 ml/min (0.001 to 15 USGPH) at 7 bar (100psi)

Total cost of ownership is less than a diaphragm pump

Typical installation comparing a diaphragm metering pump with the Qdos peristaltic metering pump

*Not required for Qdos system

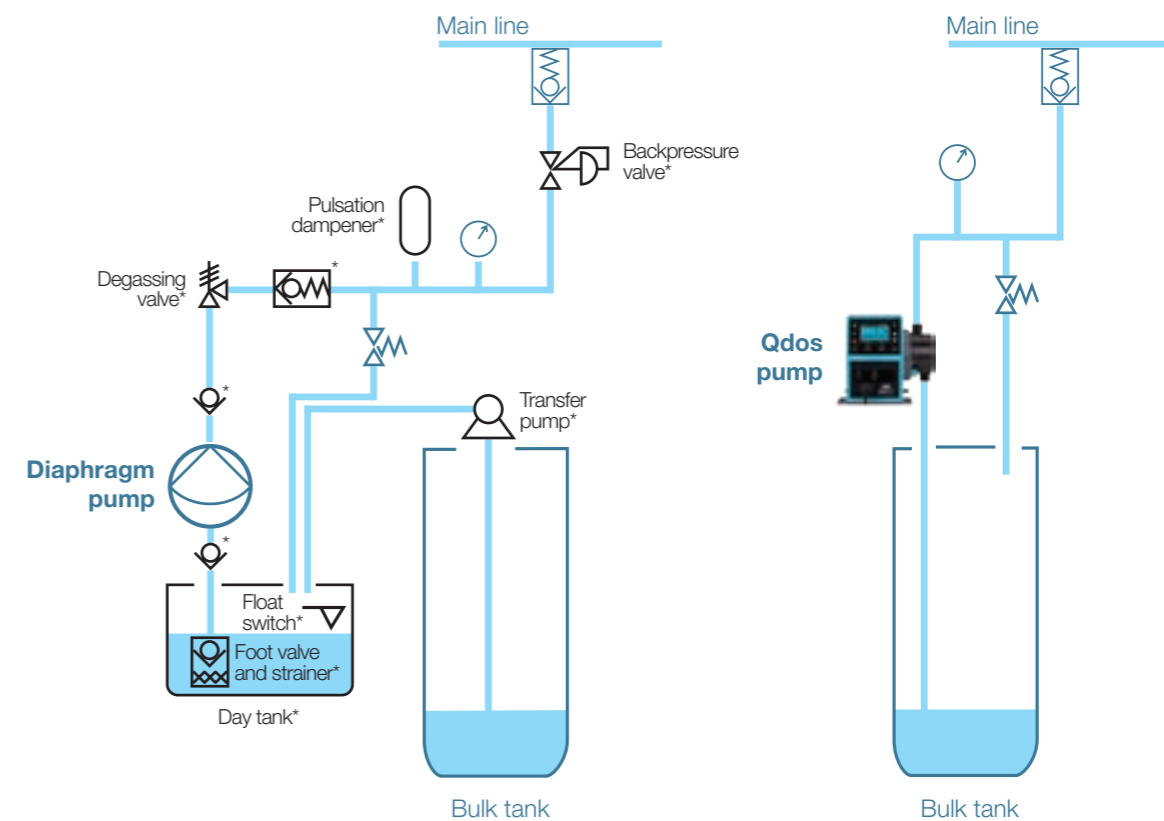

Diaphragm metering pumps require high maintenance ancillaries to function. The Qdos range eliminates this equipment while maintaining accurate, linear and repeatable metering for all process conditions.

- No backpressure valves
- No pulsation dampener
- No degassing valves
- No foot valves and strainers
- No float switches



ReNu Revolutionary pumphead technology

The unique design of the patented ReNu™ pumphead enables accurate and repeatable flow for fluids of wide ranging viscosities.

No-tools maintenance means quick, safe and easy pumphead replacement with no specialist training or maintenance technicians.

The contained pumphead design with integral leak detection reduces wastage and eliminates operator exposure to chemicals.



Optional HMI protective screen

Rugged IP66 pump drive, designed for industrial environments

Easy access high-visibility interface

Keypad and 3.5" TFT colour display provide easy access and high-visibility status indication. Configurable in 7 languages

Two models in the range

Qdos 30 and Qdos 60

Reduce your chemical costs

Accurate, linear and repeatable flow, with varying process conditions. Keeps pumping even when gassing-off occurs or when the chemical contains solids. No need to over-meter chemicals

Simplify your system design

High suction lift and viscous handling eliminates the need for flooded suction, day tanks and specialist piping systems

Safe maintenance

The sealed ReNu pumphead with integral leak detection eliminates operator exposure to chemicals. No chemicals on the floor, no parts to clean and rebuild

Replace your pump in seconds

Process uptime is maximised with **no-tools maintenance** quick and easy pumphead replacement

Low maintenance

No valves or seals to clog, leak or corrode, giving minimal maintenance. Drop-in replacement for diaphragm metering pumps





Flocculation

Flocculants can cause clogging in diaphragm pumps, increasing maintenance and process down-time.

Environmental conditions such as temperature affect fluid viscosity also affect diaphragm pump performance.

Qdos peristaltic metering pumps deliver accurate metering even with fluctuating viscosity. The powerful suction capability eliminates the need for a day tank or specialist piping schemes. There are no seals or valves in the flow path to clog or wear, meaning pump performance is never compromised.



Mineral processing – Reagent dosing

Reagent metering requires high accuracy to optimise yields.

Qdos peristaltic metering pumps deliver linear and accurate metering across the flow range, improving efficiency of flotation cells and leading to increased mineral yields.

The toxicity of reagents such as sulphuric acid and cyanides are hazardous and can damage pumps. ReNu pumphead technology ensures the safe containment. Rapid no-tools maintenance means an operator can quickly and safely change the pumphead.



Disinfection

Sodium hypochlorite creates gas locking and crystallisation in diaphragm pumps.

Flow rates and pressure changes fluctuate impacting metering accuracy. Diaphragm pumps are often set to 'over-dose' to ensure water quality is maintained. This increases chemical usage and secondary treatment to compensate.

Qdos peristaltic metering pumps deliver predictable, accurate metering at variable pressure up to 7 bar (100 psi), even with fluctuating process conditions. Gas locking and crystallisation issues are eliminated.

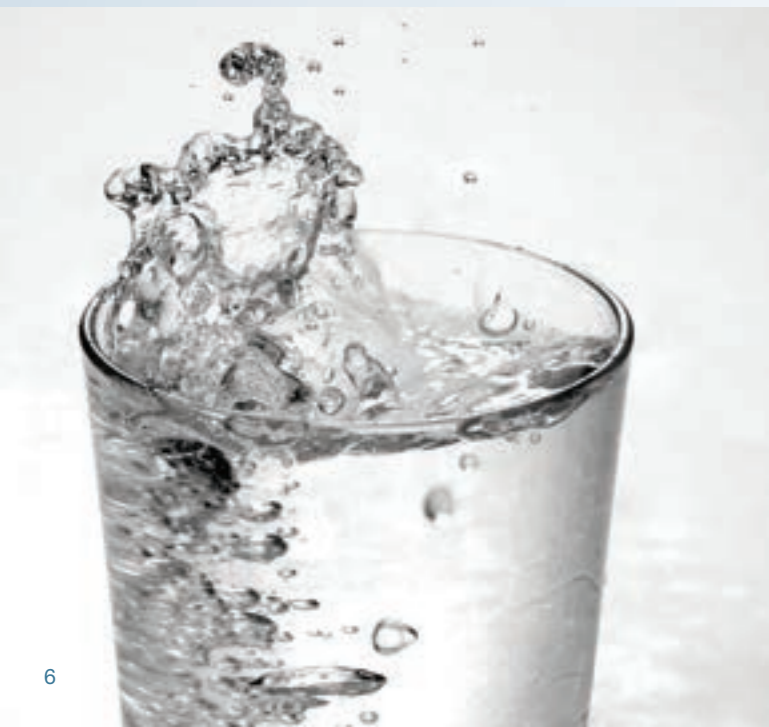

pH adjustment – Industrial water treatment

Water pH influences the effectiveness of disinfection.

Accurate pH control is critical to meet water standards and ensure process continuity. Metering alkalis such as Calcium Hydroxide creates issues with clogging and damage. Metering acids carries safety implications and can corrode pipework and equipment.

Qdos peristaltic metering pumps minimise pH 'overshoot'. Suspended solids are handled with no risk of clogging. Operator safety is ensured with the ReNu pumphead, a single safely-contained component for rapid no-tools maintenance.



Features of the Qdos range

Simplicity in installation, operation and maintenance were key considerations when designing the Qdos range of pumps.

An intuitive menu offers advanced control features including:

- Fluid level monitoring
- Line priming
- Flow calibration

The 3.5" TFT colour display provides instant pump status, and can be configured to display in 7 different languages.

Qdos pumps can be ordered with the ReNu pumphead mounted on the left or right of the pump. The keypad, display and input/output connections are readily accessible for easy operation and maintenance. All models are IP66 rated for use in washdown environments.

Qdos 30 and Qdos 60 pump range overview



Universal+	Universal	Manual
Flexibility for automatic and manual control together with configurable 4-20mA input and output	Automatic and manual control	Manual speed control



Remote	PROFIBUS
Remote control for absolute process security	Manual and PROFIBUS control



Features overview

Functionality	Universal +	Universal	Manual	Remote	PROFIBUS
Operational modes					
Manual	•	•	•		•
Contact	•	•			
4-20mA	•	•		•	
Fluid recovery	•	•	•	•	•
Fault reporting	•	•	•	•	•
PROFIBUS control and diagnostics					•
Manual control					
Numerical flow display	•	•	•		•
Numerical speed display	•	•	•		•
Numerical percentage of max speed display	•	•	•		•
Fluid level monitor	•	•	•		•
Max (prime)	•	•	•		•
Auto restart	•	•	•		•
Pumphead failure alarm	•	•	•		•
Remote control					
4-20mA input	•	•		•	
4-20mA input two point calibration	•				
4-20mA output	•			•	
Contact input (pulse/batch)	•	•			
Run stop input	•	•		•	
Run status output	•	•		•	
Alarm output	•	•		•	
Remote fluid recovery	•	•		•	
Optional 24V or 110V industrial logic*	•	•			
LED status icons					
Pump status				•	
4-20mA status				•	
Fault				•	
Security					
Keypad lock	•	•	•		•
PIN lock	•	•	•		•

Control options - Universal and Universal+ models*

Variant	Standard pump (L)
Input	5-24V DC
Output	Open collector
Variant	Relay module (H)
Input	110V AC
Output	Contact rating 110V AC, 5A 30V DC, 5A
Variant	Relay module (R)
Input	5-24V DC
Output	Contact rating 110V AC, 5A 30V DC, 5A



Standard pump (L)
Input and output control option

Relay module (H) or (R)
Input and output control option

Performance data

Model	Speed (rpm)	Flow (ml/min)	
		Qdos 30	Qdos 60
Universal+, Universal, Manual, PROFIBUS	0.025 - 125	0.1 - 500	0.1 - 1000
Remote	0.078 - 125	0.3 - 500	0.3 - 1000
		Flow (USGPH)	
Universal+, Universal, Manual, PROFIBUS	0.016 - 125	0.001 - 7.93	0.016 - 15.85
Remote	0.078 - 125	0.005 - 7.93	0.005 - 15.85

Maximum performance curves

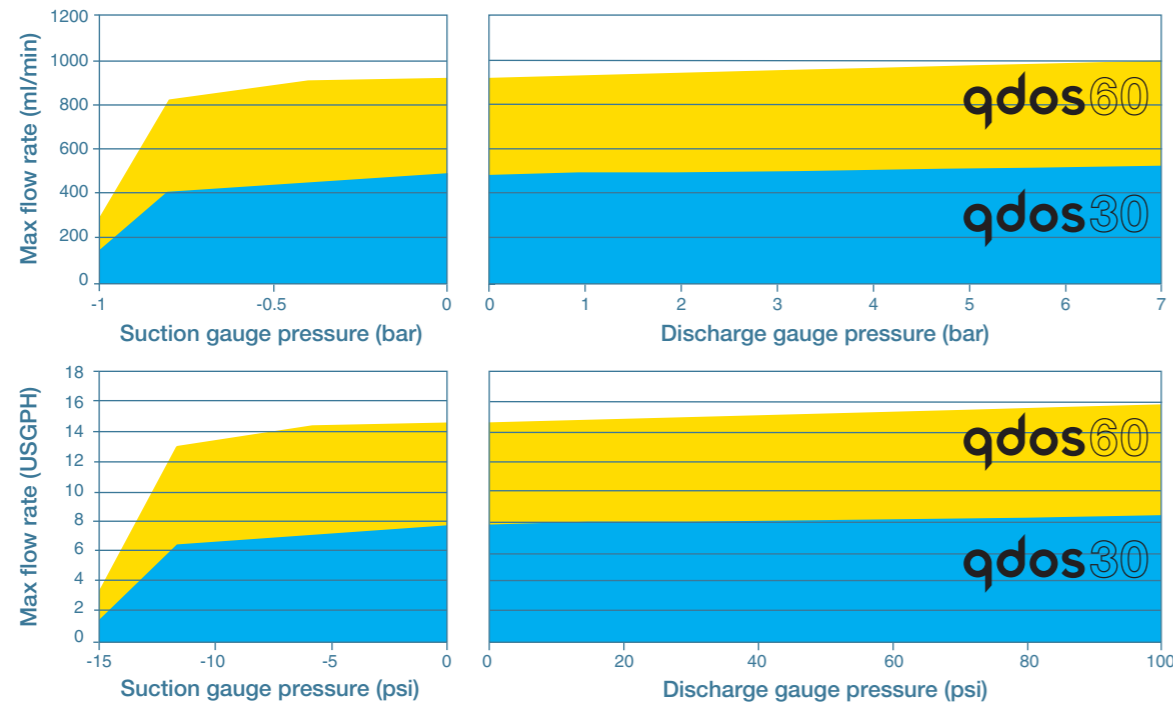

Important note - The ReNu Pumphead contains lubricant. It is the user's responsibility to comply with local health and safety regulations, including ensuring chemical compatibility between the lubricant and the duty fluid before use. For guidance refer to www.wmpg.com/chemical

Dimensions

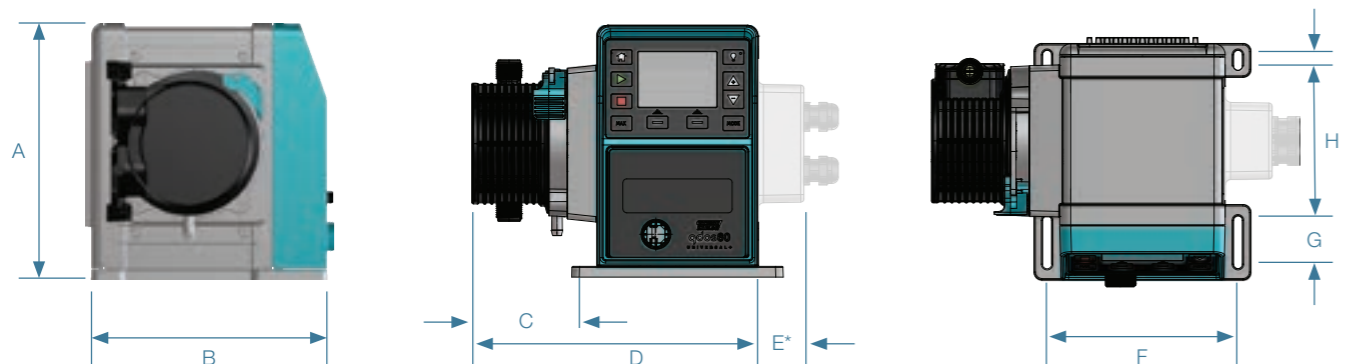

Model	A	B	C	D	E*	F	G	H	I
Qdos 30	234mm (9.2")	214mm (8.4")	82.5mm (3.2")	233mm (9.2")	43mm (1.7")	173mm (6.8")	40mm (1.6")	140mm (5.5")	10mm (0.4")
Qdos 60	234mm (9.2")	214mm (8.4")	118mm (4.6")	266mm (10.5")	43mm (1.7")	173mm (6.8")	40mm (1.6")	140mm (5.5")	10mm (0.4")

* Optional relay module

Ordering information

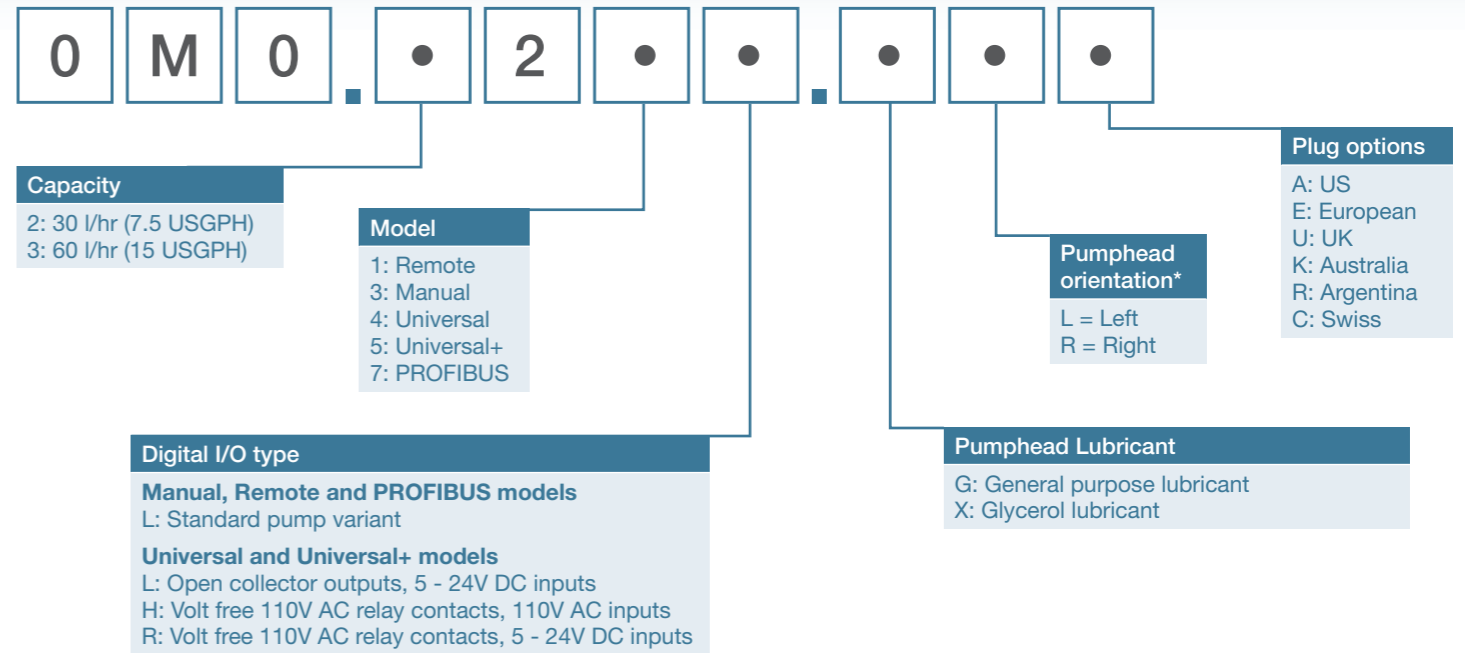

ReNu 30 pumphead	Part number
ReNu 30 pumphead (PFPE lubricant)	0M3.2200.PFP
ReNu 30 pumphead (silicone lubricant)	0M3.2200.SB0
ReNu 30 pumphead (glycerol lubricant)	0M3.2200.GLY

ReNu 60 pumphead	Part number
ReNu 60 pumphead (PFPE lubricant)	0M3.3200.PFP
ReNu 60 pumphead (silicone lubricant)	0M3.3200.SB0
ReNu 60 pumphead (glycerol lubricant)	0M3.3200.GLY

Interface tubing	Part number
PVC 6.3x11.5mm, 2m (6.5ft) length	0M9.2222.V6B
PVC 10x16mm, 2m (6.5ft) length	0M9.2222.VAD
PVC 6.3x11.5mm, 5m (16ft) length	0M9.2225.V6B
PVC 10x16mm, 5m (16ft) length	0M9.2225.VAD
Polythene, 9x12mm, 2m, (6.5ft) length	0M9.2222.E9C
Polyethylene 5x8mm, 2m (6.5ft) length	0M9.2222.E58
Polyethylene 9x12mm, 5m (16ft) length	0M9.2225.E9C
Polyethylene 5x8mm, 5m (16ft) length	0M9.2225.E58

Accessories	Part number
Hydraulic connection pack, polypropylene compression fittings	0M9.221H.P01
Hydraulic connection pack, polypropylene barb/threaded fittings	0M9.221H.P02
Replacement baseplate	0M9.223M.X00
Input lead, M12 IP66, 3m (10ft) length	0M9.203X.000
Output lead, M12 IP66, 3m (10ft) length	0M9.203Y.000
HMI protective cover	0M9.203U.000

* The pumphead side location is required when ordering. The left/right perspective assumes the user is looking at the front of the pump. The pump in the dimensions diagram on page 10 is considered a pumphead located to the left.

† Pumps are 100-240 VAC, 1ph, 50-60Hz and fitted with the mains power plug for the designated plug option.

Weight

Model	kg	lb
Qdos 30	5.0	11lb 2oz
Qdos 60	5.7	12lb 9oz

Watson-Marlow Pumps Group has seven world-class factories supported by direct sales operations in 25 countries and distributors in more than 50 countries. For contact details visit our website:

www.wmpg.com

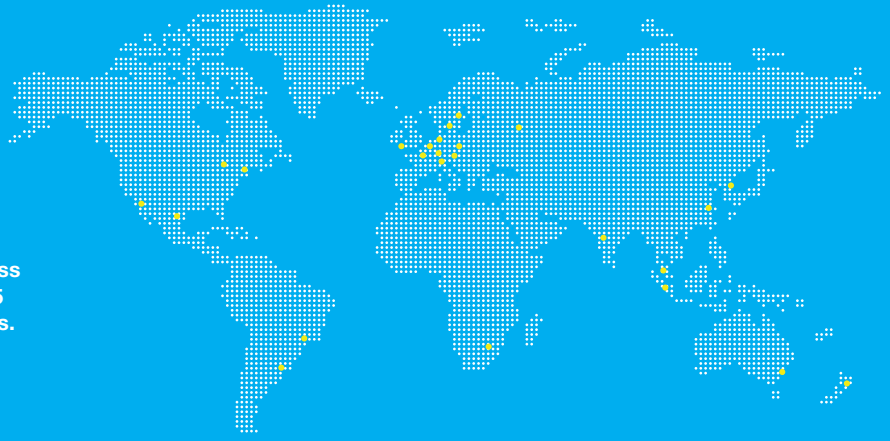

Watson-Marlow

Bredel

Flexicon

MasoSine

BioPure



Watson-Marlow online

Our engineers around the world can help you choose the perfect pump and tubing for your needs.

More information? Our brochures are on our website: www.wmpg.com

For more information on Qdos peristaltic metering pumps visit: www.qdospumps.com



Watson-Marlow... Innovation in Full Flow

Tel: +44 (0) 1326 370370
info@wmpg.co.uk

Watson-Marlow Pumps Group
Falmouth, Cornwall TR114RU, UK
www.wmpg.co.uk

All flow rates shown were obtained pumping water at 20°C (68°F) with zero suction and delivery heads.
Disclaimer: The information contained in this document is believed to be correct but Watson-Marlow Limited accepts no liability for any errors it contains and reserves the right to alter specifications without notice. It is the users responsibility to ensure product suitability for use within their application. Watson-Marlow, Qdos, ReNu, LoadSure, Bioprene, Pumpsil and Marprene are trademarks of Watson-Marlow Limited. STA-PURE PFL® and STA-PURE PCS® are registered trademarks of W.L. Gore & Associates Inc. Please state the product code when ordering pumps and tubing.