

Bredel

Hose Pumps

BREDEL HEAVY DUTY HOSE PUMPS

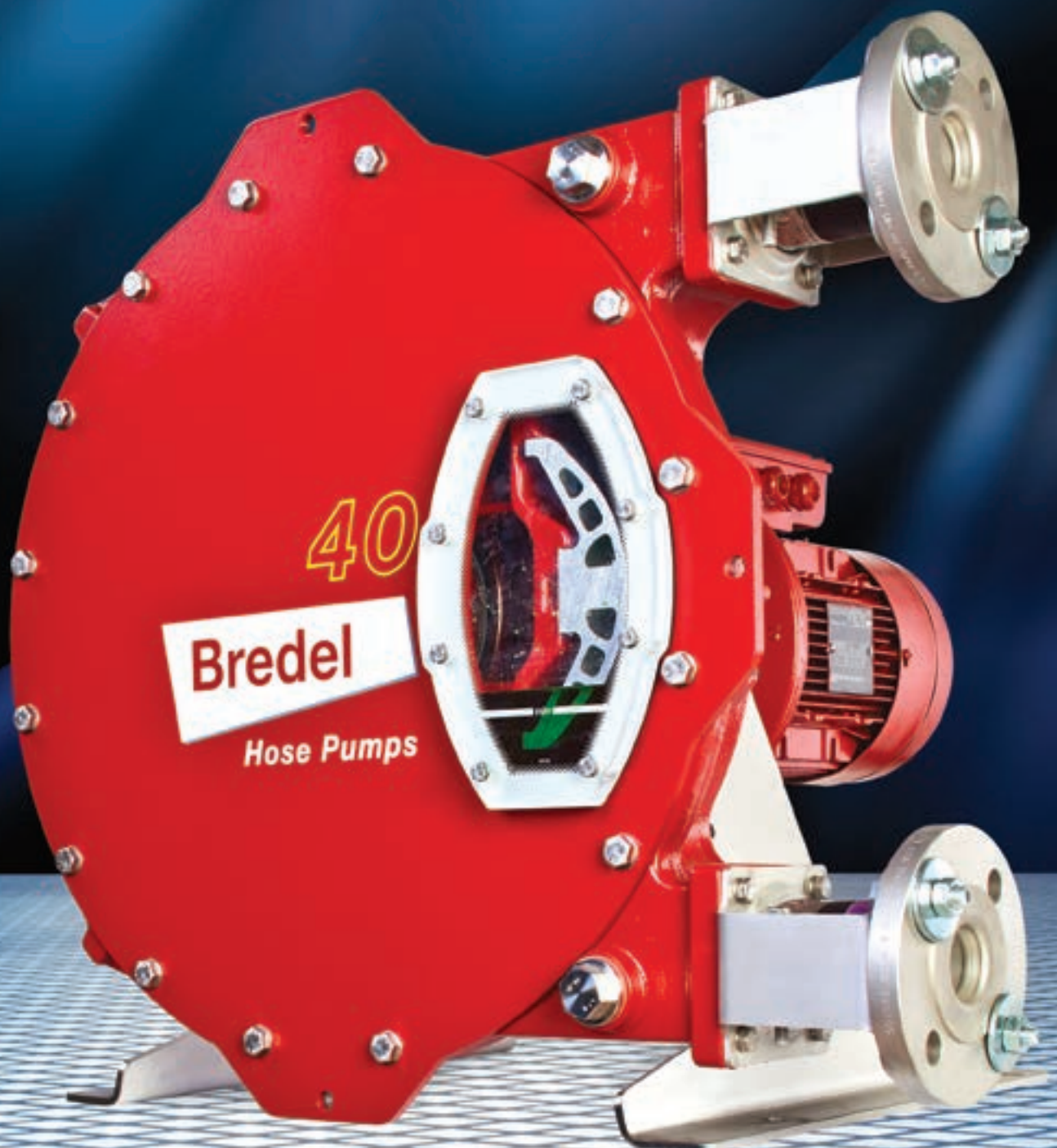

Good News... a pump with no seals or valves to wear, clog, or leak

Bredel is the world's leading manufacturer of peristaltic pumps with the largest range of pumps and pump element materials.

Today Bredel has more than 100,000 peristaltic pumps working non-stop around the globe. With operating pressures up to 16 bar and flow rates up to approximately 100 cubic metres/hour, Bredel hose pumps save time and money by successfully handling the toughest applications in a broad range of industries.

Engineered Simplicity

The pumping action results from alternately compressing and relaxing a machined hose between the pump housing and the compressing shoes. The fluid ahead of the shoe is pushed towards the discharge while the rebounding hose behind the shoe draws more fluid in. With 100% compression at all times, the pump does not slip, providing unbeatable metering accuracy and pressure performance. With no pump seals, seats or valves, abrasive slurries are no problem. With the fluid contacting only the inner wall of the hose, the pump is perfect for aggressive chemicals.

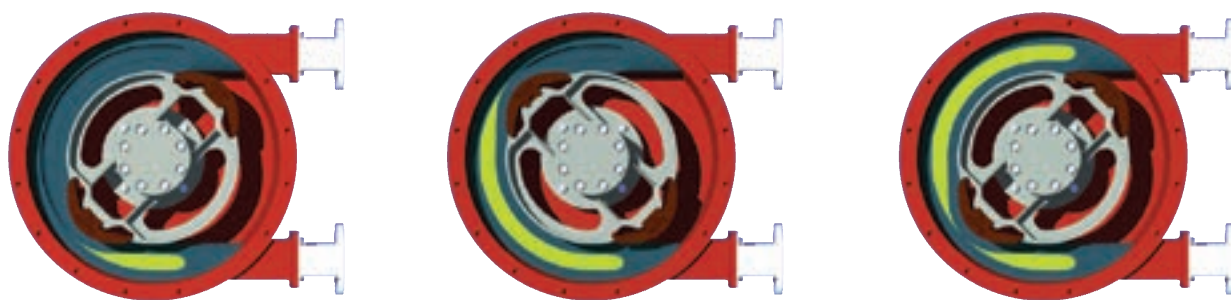

The pumping action provides unbeatable metering accuracy and pressure performance.

Save time and money

High maintenance diaphragm, rotary lobe, or progressive cavity pumps can't match the rugged, reliable 24/7 dependability of the Bredel Series:

- No ancillary equipment, check valves or sealing water flush systems
- Pumps abrasive slurries, corrosive acids, large solids and gaseous liquids with ease
- Ideal for high viscosity or shear sensitive product
- Run-dry indefinitely without damage
- EHEDG certified
- Minimal maintenance - just change the hose
- Suction lift capability up to 9.5 metres and self-priming
- $\pm 1\%$ metering accuracy

Advantages

Comparative advantages	Long-coupled	Close-coupled	Bredel direct-coupled
Ease of maintenance	x		x
Protected gearbox - lubricant seal in pumphead	x		x
Reliability - bearings in pumphead	x		x
Compact footprint		x	x
Faster installation - no drive alignment		x	x
Total	3	2	5

Chemical

Corrosive acids and bases

Water and Waste Treatment

Lime, kalic, sodium hypochlorite, ferric chloride and sludges

Paint and pigments

Dispersion mill feed, pigment and latex transfer

Pulp and Paper

dyes, sizing agents, retention aids and titanium dioxide

Mining

tailing slurries, sludges and reagents

Ceramics and glass

fine china, brick and tiles

Construction

cement, coatings, spray concrete, colorants and aggregate

Printing and packaging

varnishes, inks, coatings and adhesives

Food and beverage

CIP applications, wine, brewery, dairy, bakery, flavorings and additives

Textiles

fibers, dyes and acids

OEM

versions available for system suppliers



Fully protected drive

Using direct coupled technology, Bredel combines the reliability of long-coupled pumps with the compact footprint of close-coupled pumps. Heavy duty rotor bearings within the pump rotor and an innovative buffer zone protect gearing from overhung loads and contamination.

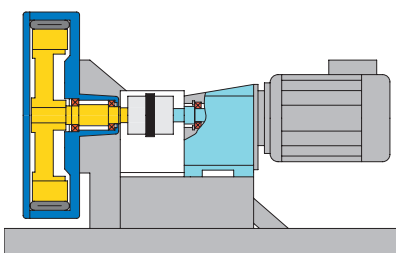

Long-coupled

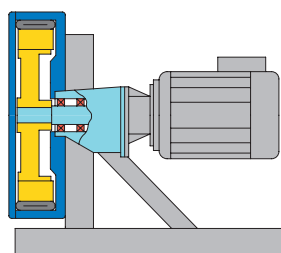

Close-coupled

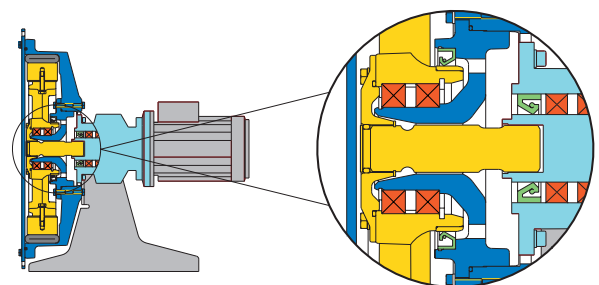

Bredel direct-coupled

Bredel 10, Bredel 15, Bredel 20

Performance

Bredel 10

Max flow: 160 litre/hour
 Capacity: 0.022 litre/rev
 Max discharge pressure: 12 bar
 Max temperature: 80C
 Inner diameter pump element: 10mm
 Lubricant required: 0.25 litres
 Starting torque: 47 Nm

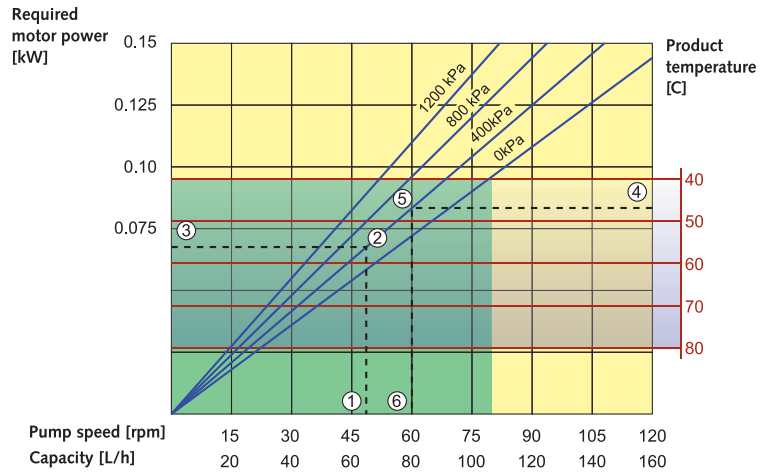

Bredel 15

Max flow: 525 litre/hour
 Capacity: 0.083 litre/rev
 Max discharge pressure: 12 bar
 Max temperature: 80C
 Inner diameter pump element: 15mm
 Lubricant required: 0.5 litres
 Starting torque: 60 Nm

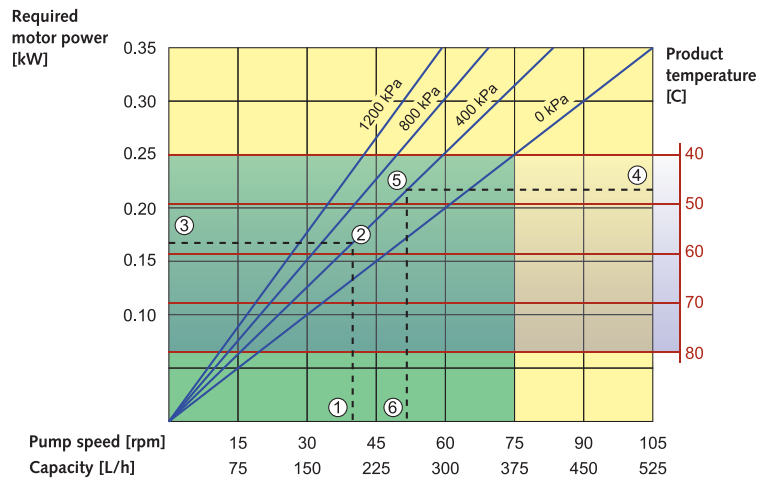

Bredel 20

Max flow: 820 litre/hour
 Capacity: 0.152 litre/rev
 Max discharge pressure: 10 bar
 Max temperature: 80C
 Inner diameter pump element: 20mm
 Lubricant required: 0.5 litres
 Starting torque: 85 Nm

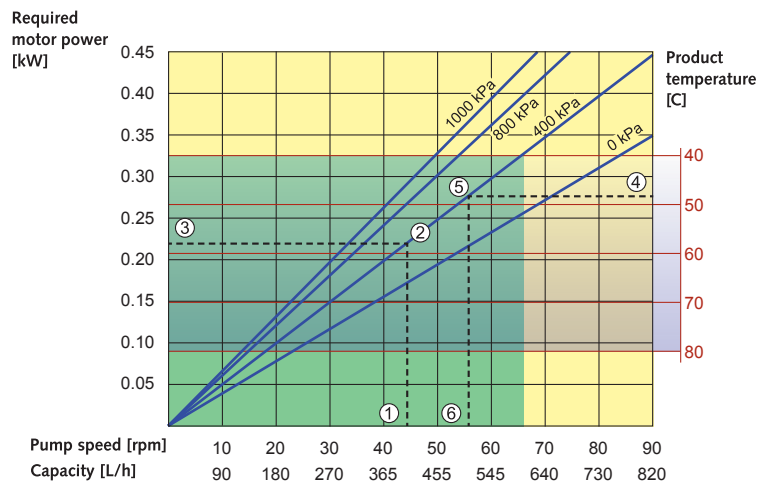

*Location is "E" noted on dimensional drawing on next page

■ Continuous Duty
 ■ Intermittent Duty (maximum 2 hours of operation followed by a minimum 1 hour stop)

Dimensions

Note: measurements in mm

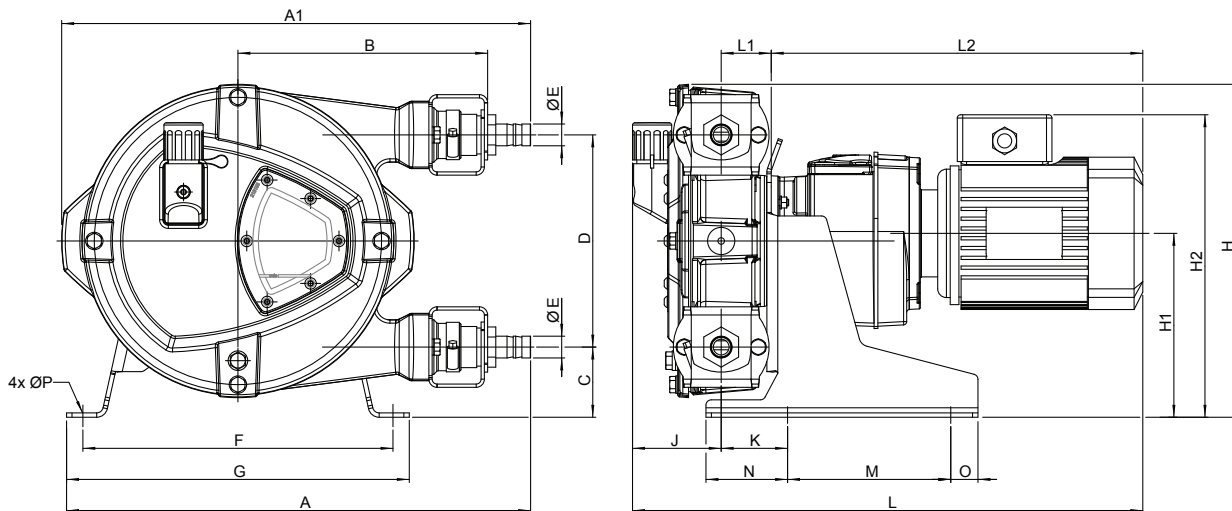

Type	A	A1	B	C	D	E	F	G	H	H1	H2 _{max}	J	K	L _{max}	L1	L2 _{max}	M	N	O	P
Bredel 10	337	311	171	62	116	Ø16	235	265	225	127	254	78	51	501	46	378	150	65	25	Ø12
Bredel 15	427	431	230	63	195	Ø20	285	315	304	167	294	82	61	505	46	378	150	75	25	Ø12
Bredel 20	427	431	230	63	195	Ø20	285	315	304	167	294	82	61	505	46	378	150	75	25	Ø12

How to use the curves

1. Flow required indicates pump speed
2. Calculated discharge pressure
3. Net motor power required
4. Product temperature
5. Calculated discharge pressure
6. Maximum recommended pump speed

Note: The area of continuous operation diminishes with increased product temperatures. For product temperatures >40C, the area of continuous operation reduces to the corresponding red temperature line.

Chemical metering

At a water treatment plant, influent is received through several very long pipelines. After preliminary processing, the influent goes through a scrub-down to reduce hydrogen sulfide content from as much as 250 ppm to less than 0.1 ppm. Diaphragm and PC pumps were replaced after experiencing long downtimes, high maintenance costs and poor performance. Bredel hose pumps are used in this process to transfer and meter sodium hypochlorite, sodium hydroxide, and sodium bisulphate.



Bredel 25, Bredel 32

Performance

Bredel 25

Max flow: 2,740 litre/hour
 Capacity: 0.300 litre/rev
 Max discharge pressure: 16 bar
 Max temperature: 80C
 Inner diameter pump element: 25mm
 Lubricant required: 1.5 litres
 Starting torque: 115 Nm

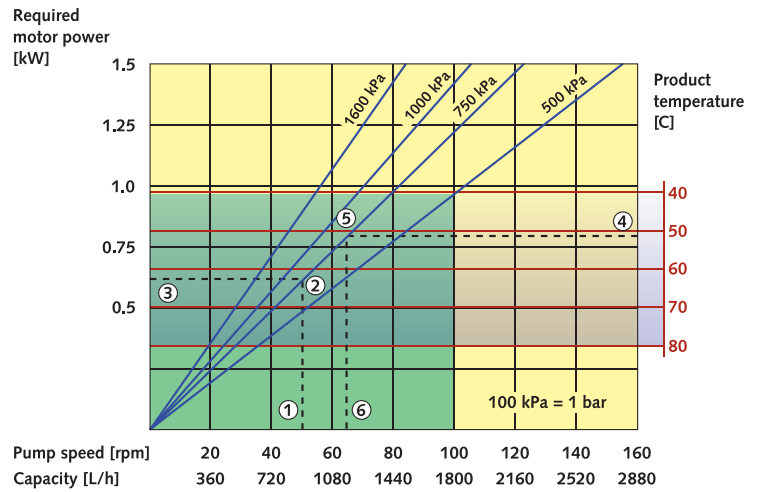

Bredel 32

Max flow: 5,250 litre/hour
 Capacity: 0.625 litre/rev
 Max discharge pressure: 16 bar
 Max temperature: 80C
 Inner diameter pump element: 32mm
 Lubricant required: 3.5 litres
 Starting torque: 210 Nm

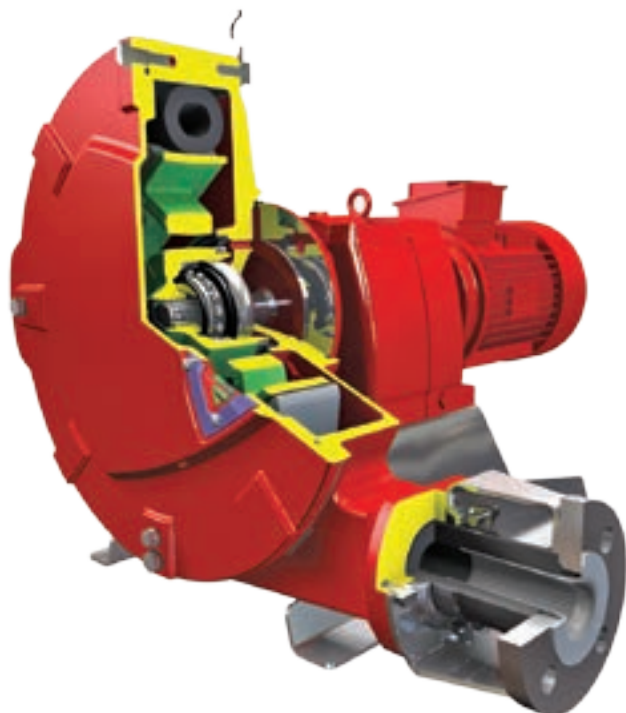
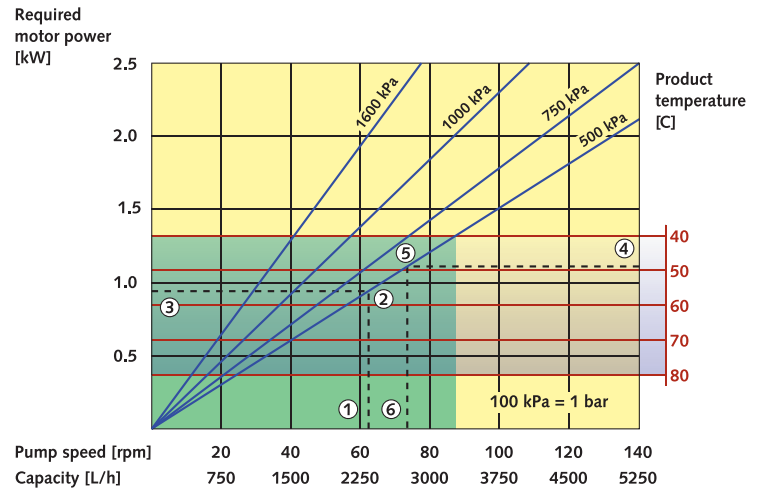

■ Continuous Duty
■ Intermittent Duty (maximum 2 hours of operation followed by a minimum 1 hour stop)

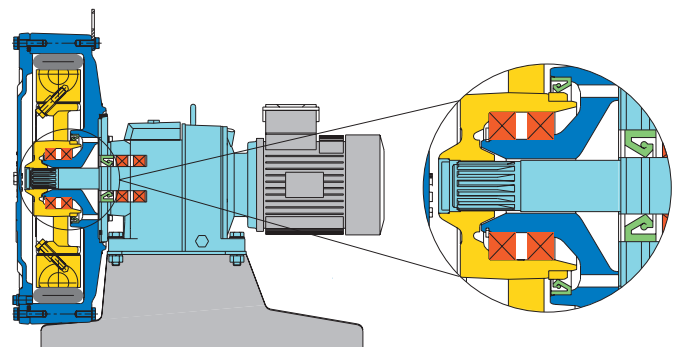

Dimensions

Note: measurements in mm

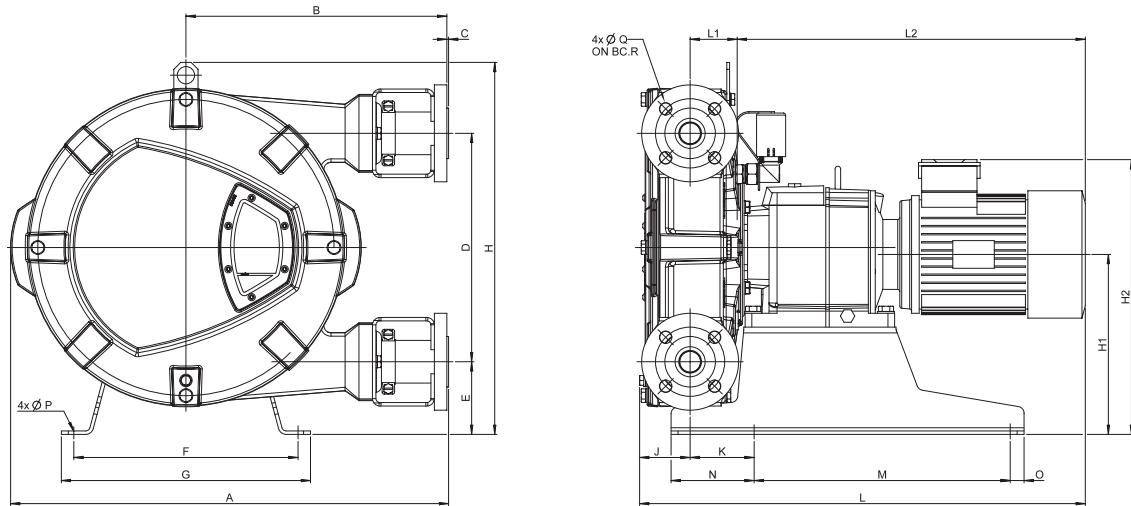

Type	A	B	C	D	E	F	G	H	H1	H2 max	J	K	L max	L1	L2 max	M	N	O	P	Q	R
Bredel 25	521	304	2.5	264	98	279	315	460	222	359	66	97	592	58	468	305	120	15	Ø12	Ø14	85
Bredel 32	631	375	2.5	330	105	324	360	538	260	402	72	93	684	68	544	370	120	20	Ø12	Ø18	100

How to use the curves

1. Flow required indicates pump speed
2. Calculated discharge pressure
3. Net motor power required
4. Product temperature
5. Calculated discharge pressure
6. Maximum recommended pump speed

Note: The area of continuous operation diminishes with increased product temperatures. For product temperatures >40C, the area of continuous operation reduces to the corresponding red temperature line.

Abrasive slurries in brewing

A leading brewer had been using diaphragm pumps to meter highly abrasive diatomaceous earth slurry but was experiencing high downtime due to abrasive wear. The brewer replaced these pumps with Bredel hose pumps, dramatically reducing maintenance and all but eliminated downtime. Based on this success, the brewer installed 6 hose pumps to transfer abrasive slurry of spent yeast. The pumps replaced rotary lobe pumps which required excessive maintenance to replace mechanical seals and lobes.



Bredel 40, Bredel 50

Performance

Bredel 40

Max flow: 9,600 litre/hour
 Capacity: 1.33 litre/rev
 Max discharge pressure: 16 bar
 Max temperature: 80C
 Inner diameter pump element: 40mm
 Lubricant required: 5 litres
 Starting torque: 320 Nm

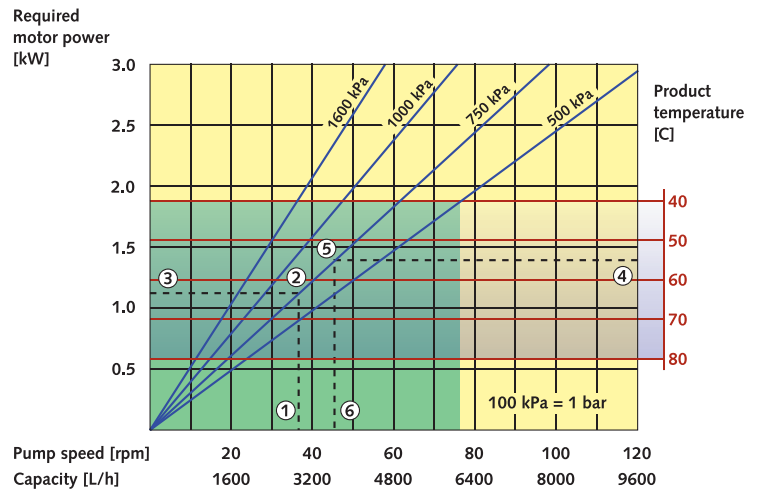

Bredel 50

Max flow: 17,500 litre/hour
 Capacity: 2.92 litre/rev
 Max discharge pressure: 16 bar
 Max temperature: 80C
 Inner diameter pump element: 50mm
 Lubricant required: 10 litres
 Starting torque: 620 Nm

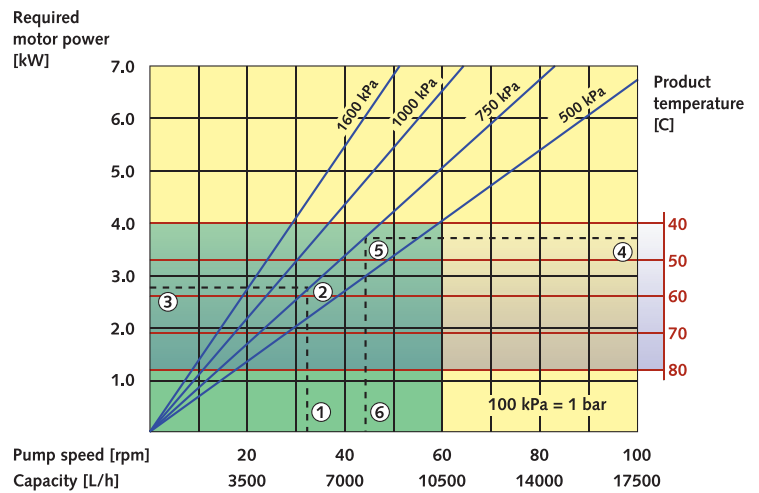

- Continuous Duty
- Intermittent Duty (maximum 2 hours of operation followed by a minimum 1 hour stop)

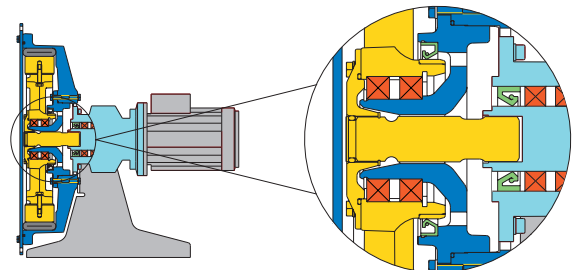
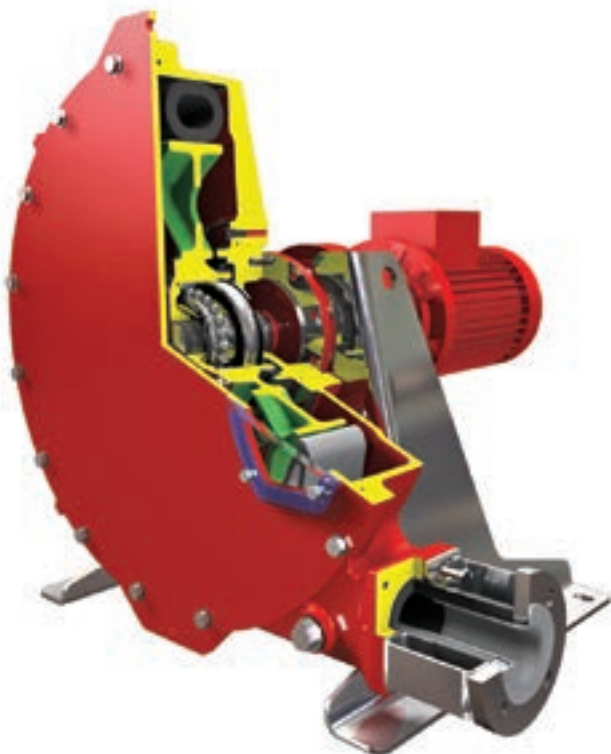

Dimensions

Note: measurements in mm

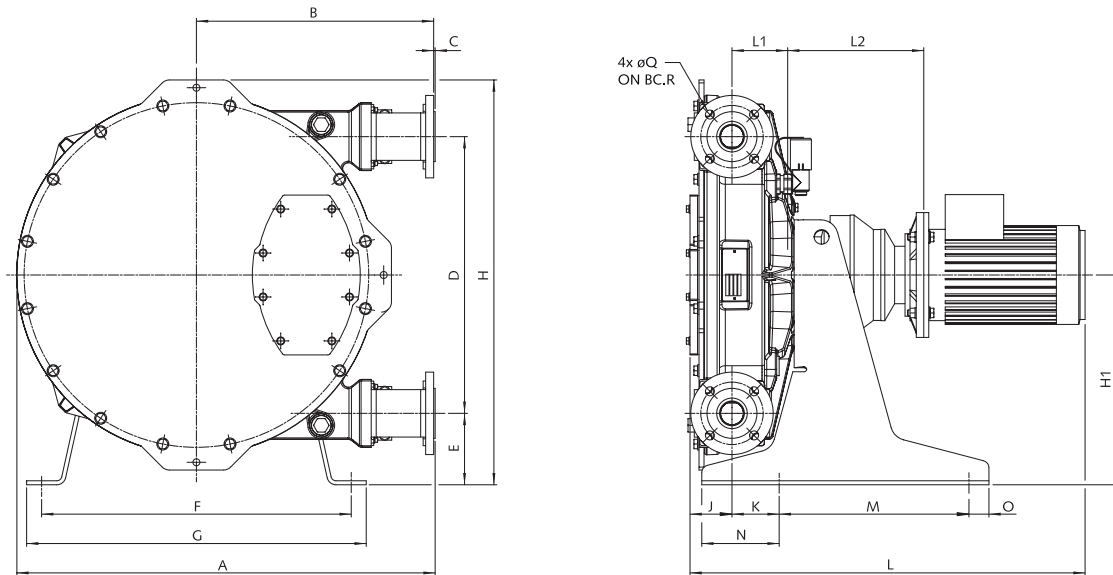

Type	A	B	C	D	E	F	G	H	H1	J	K	L _{max}	L1	L2 _{max}	M	N	O	P	Q	R
Bredel 40	705	412	2.5	430	110	490	540	643	325	73	84	906	91	301	300	120	30	Ø18	Ø18	110
Bredel 50	838	475	3	554	143	620	680	811	420	84	95	975	112	339	380	155	40	Ø18	Ø18	125

How to use the curves

1. Flow required indicates pump speed
2. Calculated discharge pressure
3. Net motor power required
4. Product temperature
5. Calculated discharge pressure
6. Maximum recommended pump speed

Note: The area of continuous operation diminishes with increased product temperatures. For product temperatures >40C, the area of continuous operation reduces to the corresponding red temperature line.

No aeration

A plant that produces fine quality bone china was using a two-stroke reciprocating type piston pump to transfer slip from the slip house to the casting shop. Due to entrained air in the slip, pinholes were forming in the surface of the cast body, which was impairing the quality of the finished product. The slip is thixotropic and highly abrasive. Changing over to a peristaltic pump eliminated this problem. Its glandless construction prevented the ingress of air.



Bredel 65, Bredel 80, Bredel 100

Performance

Bredel 65

Max flow: 32,200 litre/hour
 Capacity: 6.7 litre/rev
 Max discharge pressure: 16 bar
 Max temperature: 80C
 Inner diameter pump element: 65mm
 Lubricant required: 20 litres
 Starting torque: 1150 Nm

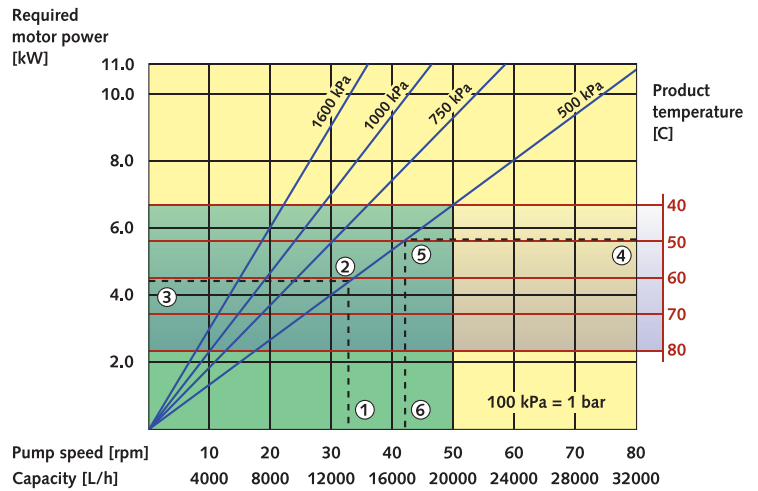

Bredel 80

Max flow: 39,100 litre/hour
 Capacity: 11.7 litre/rev
 Max discharge pressure: 16 bar
 Max temperature: 80C
 Inner diameter pump element: 80mm
 Lubricant required: 40 litres
 Starting torque: 2000 Nm

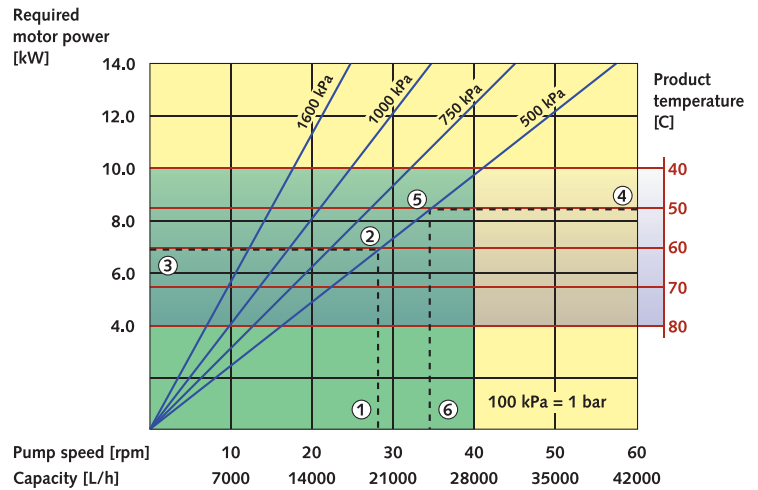

Bredel 100

Max flow: 52,900 litre/hour
 Capacity: 20 litre/rev
 Max discharge pressure: 16 bar
 Max temperature: 80C
 Inner diameter pump element: 100mm
 Lubricant required: 60 litres
 Starting torque: 3100 Nm

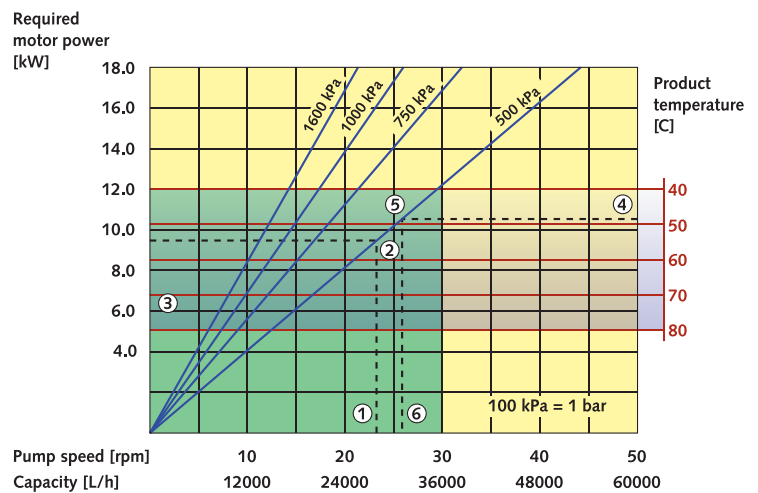

■ Continuous Duty
 ■ Intermittent Duty (maximum 2 hours of operation followed by a minimum 1 hour stop)

Dimensions

Note: measurements in mm

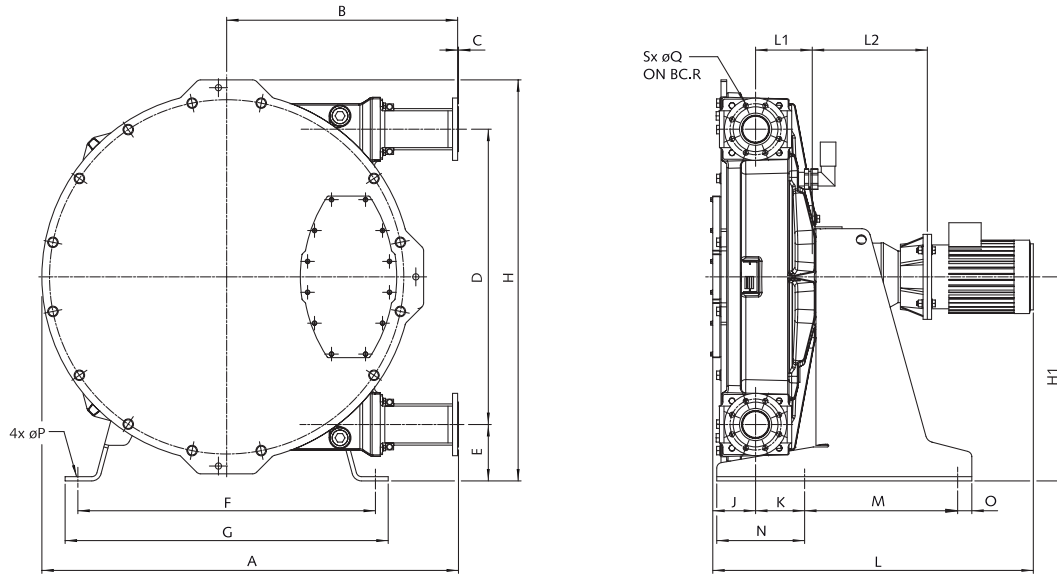

Type	A	B	C	D	E	F	G	H	H1	J	K	L _{max}	L1	L2 _{max}	M	N	O	P	Q	R	S
Bredel 65	1059	580	3	746	152	680	740	1036	525	104	137	1172	141	486	415	220	50	Ø18	Ø18	145	4
Bredel 80	1257	700	4	876	182	900	990	1218	620	124	153	1351	166	582	525	275	50	Ø22	Ø18	160	8
Bredel 100	1468	813	3	1042	199	1050	1140	1415	720	151	173	1392	200	489	540	310	50	Ø22	Ø18	180	8

How to use the curves

1. Flow required indicates pump speed
2. Calculated discharge pressure
3. Net motor power required
4. Product temperature
5. Calculated discharge pressure
6. Maximum recommended pump speed

Note: The area of continuous operation diminishes with increased product temperatures. For product temperatures >40C, the area of continuous operation reduces to the corresponding red temperature line.

Solids - no problem

When wood chips are cooked in a digestion liquid, a treated residue known as black liquor soap is derived from the digestion process. Paper mills usually use a large gear pump or other rotary type pump to handle this soap, often with considerable difficulty. Suction problems, dry running, and small wood particles only make things worse. The Bredel hose pump provides the optimum solution: It is abrasive resistant, very capable of handling solids, and because there are no shaft seals, it is allowed to run dry.



Bredel 280, Bredel 2100

Performance

Bredel 280

Max flow: 78,000 litre/hour
 Capacity: 23.4 litre/rev
 Max discharge pressure: 16 bar
 Max temperature: 80C
 Inner diameter pump element: 80mm
 Lubricant required: 80 litres
 Starting torque: 3,400 Nm

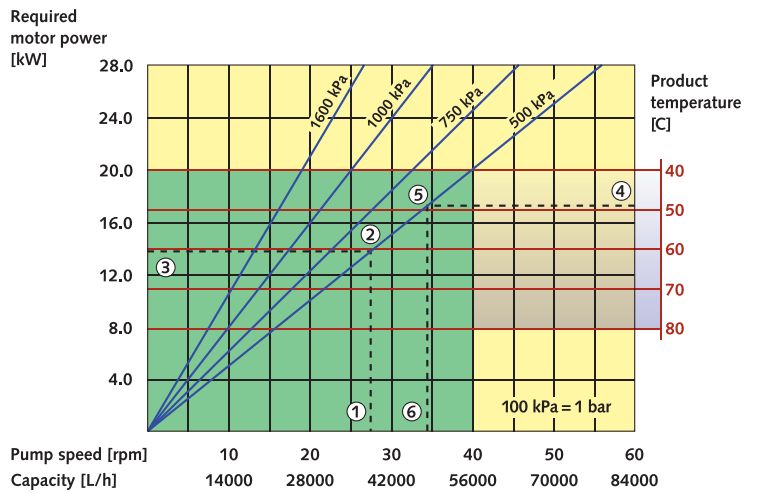

Bredel 2100

Max flow: 108,000 litre/hour
 Capacity: 40 litre/rev
 Max discharge pressure: 16 bar
 Max temperature: 80C
 Inner diameter pump element: 100mm
 Lubricant required: 120 litres
 Starting torque: 5,300 Nm

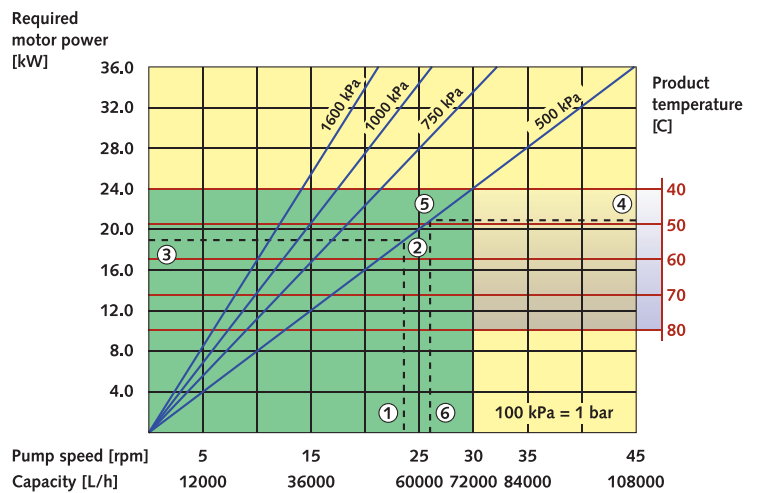

■ Continuous Duty
 ■ Intermittent Duty (maximum 2 hours of operation followed by a minimum 1 hour stop)



* For more information, please consult your Bredel representative. Duplex executions are also available for the Bredel 10 up to Bredel 65 series pumps.

Very limited floor space required.

Dimensions

Note: measurements in mm

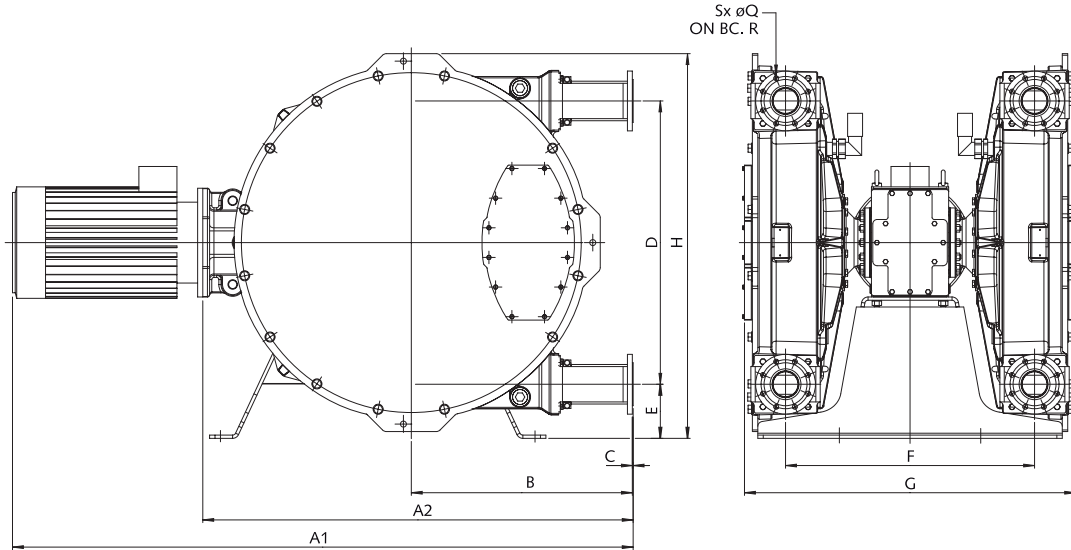

Type	A1	A2	B	C	D	E	F	G	H	Q	R	S
Breidel 280	*	1404	700	4	876	182	800	1047	1218	Ø18	160	8
Breidel 2100	*	1516	813	3	1042	199	916	1218	1415	Ø18	180	8

* This dimension will vary depending on drive selection.

How to use the curves

1. Flow required indicates pump speed
2. Calculated discharge pressure
3. Net motor power required
4. Product temperature
5. Calculated discharge pressure
6. Maximum recommended pump speed

Note: The area of continuous operation diminishes with increased product temperatures. For product temperatures >40C, the area of continuous operation reduces to the corresponding red temperature line.

High flow

A large mining company needed several pumps to transfer sludge with flow rates up to 68 m3/h. The unique duplex hose pump was the solution for this application. This unit has two pump heads mounted on a single drive. With the pump shoes positioned at 90 degree intervals, the pump is capable of producing higher flow rates than a single pump, but with much smaller power and space requirements than two pumps.



DuCoNite[®] - the answer for aggressive liquids

The **DuCoNite** pump is used for the most challenging applications. A high-tech surface-protection method has rendered the pump ultra-resistant to aggressive liquids.

The DuCoNite hose pumps are available in five pump sizes - with capacities up to 5,250 litre/hour and pressures up to 16 bar.

The DuCoNite hose pump reliably handles a variety of harsh materials, such as sodium hypochlorite, titanium dioxide, sodium hydroxide, catalytic agents, sulfuric acid, lime slurry, acidic liquids, solvents and resins.



DuCoNite Advantage

Bredel hose pumps require minimal maintenance; to completely rebuild a Bredel pump simply change the hose. When protecting the pump is still a concern, the DuCoNite pump gives you the added advantage:

“Beyond the hose” protection against common water and waste water treatment chemicals

Paint-free pump housing perfect for wash-down in the food industry

Available in DuCoNite 10, DuCoNite 15, DuCoNite 20, DuCoNite 25, and DuCoNite 32 pumps for metering and transfer.



DuCoNite 10

Maximum flow: 145 litre/hour
Maximum discharge pressure: 7.5 bar

DuCoNite 15

Maximum flow: 820 litre/hour
Maximum discharge pressure: 7.5 bar

DuCoNite 20

Maximum flow: 954 litre/hour
Maximum discharge pressure: 7.5 bar

DuCoNite 25

Maximum flow: 2,498 litre/hour
Maximum discharge pressure: 16 bar

DuCoNite 32

Maximum flow: 5,250 litre/hour
Maximum discharge pressure: 16 bar

DuCoNite®

Chemical Duty Protection

Developed and tested by Bredel in conjunction with expert metallurgists, DuCoNite is a three step metallic surface treatment process with proven excellent chemical resistance to a myriad of chemicals, including many of the common aggressive fluids pumped by hose pumps around the globe:

Chemical	Concentration	Fluid Temp	Resistance
Sodium Hypochlorite	up to 18%	21-50C	A
Sodium Bisulfite	38%	21-50C	A
Ferric Chloride	up to 50%	21-50C	A
Ferrous Chloride	35%	21-50C	A
Alum	50%	21-50C	A
Hydrofluosilicic Acid	18-24%	21-50C	B
Sodium Hydroxide	20-50%	21-50C	A
Potassium Permanganate	50%	21-50C	A
Aqueous Ammonia	20%	21-50C	B
Sulfuric Acid	93-97%	21-50C	A
Citric Acid	50%	21-50C	A
Zincorthophosphate	25%	21-50C	A
Phosphoric Acid	50%	21-50C	A
Nitric Acid	25%	21-50C	A

Chemical compatibility
A = Good B = Limited

For dimensional drawings, please see pages 8-11.

Solids Handling

A producer of polycarbonate resin pellets, was experiencing problems pumping effluent. The strips had become trapped in the double-diaphragm pump the company was using to transport the effluent to a filter press.

Constantly blocked, the diaphragm pump was, in effect, acting as a filter. The Bredel hose pump now transfers the effluent easily, virtually eliminating downtime. It has also improved the effectiveness of the filter press by as much as 35 times.



Clean-In-Place: Bredel CIP 40, Bredel CIP 50

Performance

Bredel CIP 40

Maximum flow: 4,800 litre/hour
 Capacity: 1.33 litre/rev
 Maximum discharge pressure: 16 bar
 Inner diameter pump element: 40mm
 Lubricant required: 10 litres
 Minimum starting torque: 320 Nm

Bredel CIP 50

Maximum flow: 8,500 litre/hour
 Capacity: 2.92 litre/rev
 Maximum discharge pressure: 16 bar
 Inner diameter pump element: 50mm
 Lubricant required: 20 litres
 Minimum starting torque: 620 Nm

Features of CIP Pumps

Recommended for sanitary processes, or other applications requiring regular cleaning of the process lines.

- Maximum sterilization temperature 120 C
- EHEDG certified
- Food approved pump element available
- NSF® registered food grade lubricant
- Stainless steel sanitary connectors available
- Process pressures up to 16 bar
- Shoes on the rotor retract automatically for cleaning of pump element inside
- Cam actuated electrically, pneumatically or manually

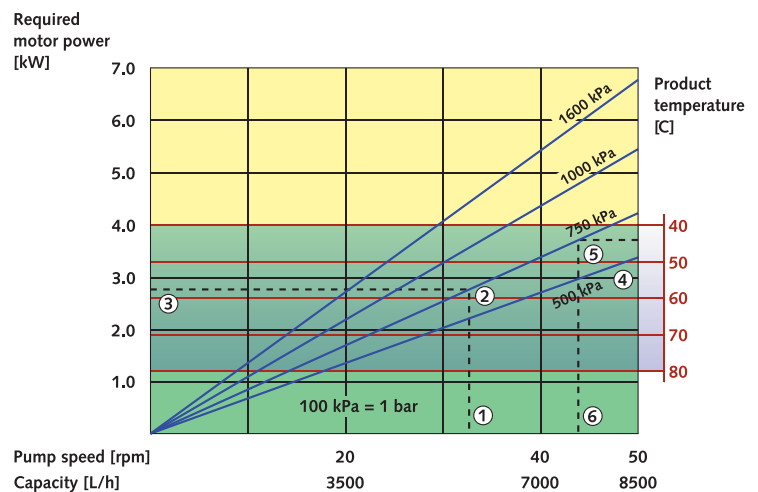
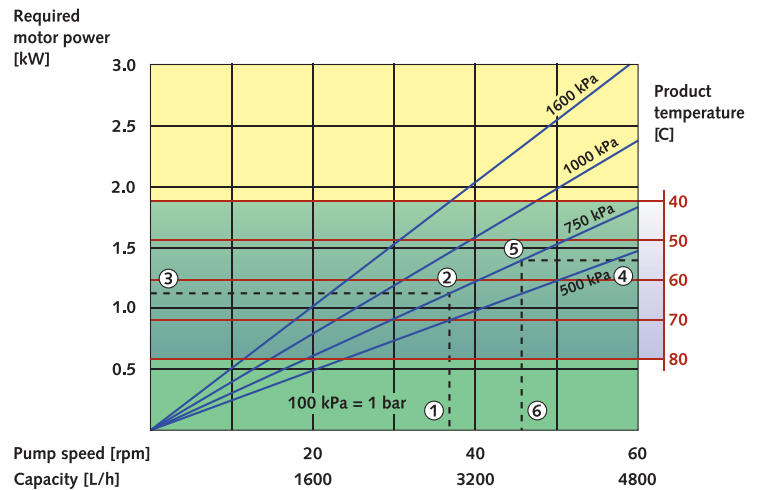

- Continuous Duty
- Intermittent Duty (maximum 2 hours of operation followed by a minimum 1 hour stop)

Dimensions

Note: measurements in mm

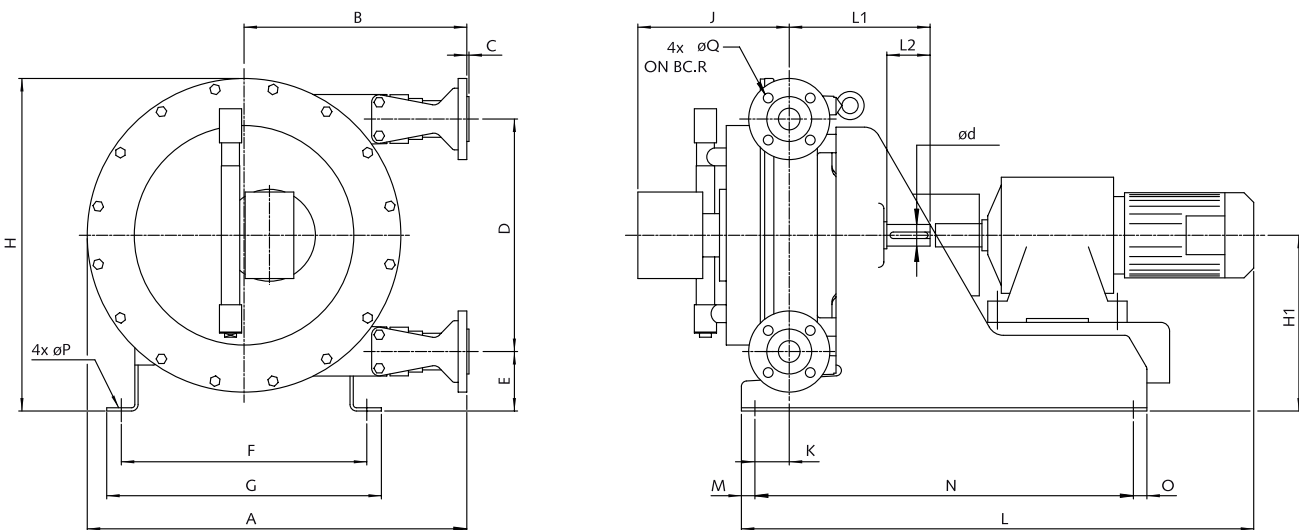

ANSI 316	PVC/PP/PVDF
----------	-------------

Type	A	B	C	C	D	Ød _{xl}	E	F	G	H	H1	J _{max}	K	L	L1	L2	M	N	O	Q	R
Bredel CIP 40	702	412	2,5	10	430	40k6x80	110	454	508	615	325	414	64	*	260	80	25	700	25	18	110
Bredel CIP 50	835	475	3	10	554	50k6x100	123	444	496	760	400	433	78	*	325	100	25	870	25	18	125

How to use the curves

1. Flow required indicates pump speed
2. Calculated discharge pressure
3. Net motor power required
4. Product temperature
5. Calculated discharge pressure
6. Maximum recommended pump speed

Note: The area of continuous operation diminishes with increased product temperatures. For product temperatures >40C, the area of continuous operation reduces to the corresponding red temperature line.

The Bredel CIP 40 and 50 are supplied with the retracting shoes option for non-intrusive cleaning, for CIP-applications.

Shear sensitive

A canning operation uses a Bredel hose pump to transfer peaches from holding tanks to its canning line. The company had been using centrifugal pumps, but was experiencing a high percentage of damaged peaches. The soft pumping action of the peristaltic pump eliminates shear and has dramatically reduced the amount of damaged or unacceptable production.

The company also likes the dependability, low maintenance and ability of the pump to run 24/7 throughout the entire canning season.



The hose is the key

The machined hose is the single most vital component for the performance, durability, and efficiency of the hose pump. To ensure perfect compression and consistent, reliable performance, Bredel manufactures hoses from high quality compounded rubbers, reinforced with four individual layers of braided nylon and finished by high precision machining. Perfect compression eliminates slip which, in other pumps, can destroy shear sensitive product, reduce metering accuracy, or allow abrasive slurries to wreak havoc on wetted parts. Bredel engineers hoses to meet the flow, pressure and temperature characteristics of your toughest applications.



- 1 Inner layer in various types of rubber
- 2 Reinforced with layers of nylon
- 3 Outer layer precision-machined
- 4 Rough outer surface before machining

Designed to perfection

Bredel is on the cutting edge of technology to engineer, manufacture and test our pumps.

Innovation: As the global leader in hose pumps, we pride ourselves on new ideas and innovative products that bring the benefits of hose pumps to our customers in an ever expanding range of applications. For example, retractable pressing shoes bring ultimate clean-in-place capability.

Design: Using tools like finite element analysis (FEA), we design our hoses to perfection - right down to the position of the reinforcing layers, angles and thickness of the cord reinforcement, and the thickness of the rubber. Everything from the geometry of the pressing shoe to the pump housing is engineered to optimize the performance of the hose.

Production: Unique in the world, Bredel's state-of-the-art automated hose grinding facility machines every hose within fine tolerances - guaranteeing proper compression for efficiency and longevity. At our ISO9001:2000 factory, each pump and hose is constructed to the most rigorous quality controls standards.

Hose construction

The essential component of high-performance hose pumps is a hose that is constructed of layers of rubber reinforced by winding several layers of nylon cords. The inner and outer layers are extruded. The inner layer is available in a range of rubber compounds. After the hose is constructed, it is then machined. Machining is the final step in hose manufacture and is critical to insure that exact tolerances are held.

Precision hose ensure

- Tight tolerances for low stress on bearings
- Perfect compression for long life
- Consistent capacity independent of varying suction and discharge conditions



Because even a 1mm variation in wall thickness can impact hose life by 25%, every hose is precision machined to ensure repeatable performance.

Hose options



NATURAL RUBBER (NR)

Outstanding abrasion resistance. Generally resistant to diluted acids and alcohols.

Max. fluid temp 80C
Min. fluid temp -20C



BUNA N (NBR)

Meets FDA and 3A. Resistant to oils, greases, alkalis and detergents.

Max. fluid temp 80C
Min. fluid temp -10C



EPDM

Excellent chemical resistance, especially to ketones, alcohols and concentrated acids.

Max. fluid temp 90C
Min. fluid temp -10C



CSM

Outstanding chemical resistance to highly concentrated acids and bases.

Max. fluid temp 80C
Min. fluid temp -10C

Accessories

1. Discharge Pulsation Dampener

Fitting a pulsation dampener in the discharge line eliminates up to 90% of discharge pulsations, protecting the pump, pipeline and instrumentation and reducing vibration, hammer and noise.



2. Inlet Pulse Accumulator (IPA)

When installed on the suction side, an IPA reduces positive and negative spikes when inlet conditions vary. This results in quieter operation and maximised hose life.



3. High Level Sensor

When connected to a motor controller, the high level sensor can trigger a pump shutdown in the event of a hose element failure.

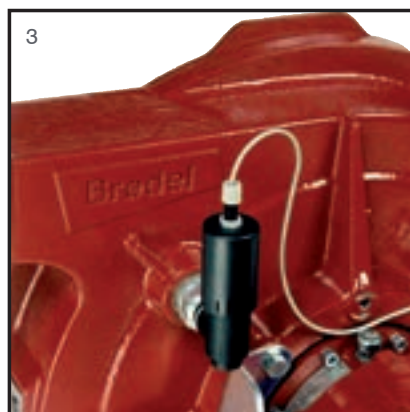

4. Variable Frequency Drive (VFD)

An integrated frequency inverter, with variable speed control, for use where pump capacity must be flexible or the process needs to be set.

Additional Accessories

Please contact Bredel for information on other accessories including the vacuum assist option for use with high viscosity fluids and the revolution sensor for monitoring your pump.

Watson-Marlow Pumps Group has six world-class factories supported by direct sales operations in 23 countries and distributors in more than 50 countries. For contact details visit our website:

www.wmpg.com



Watson-Marlow Bredel Flexicon MasoSine

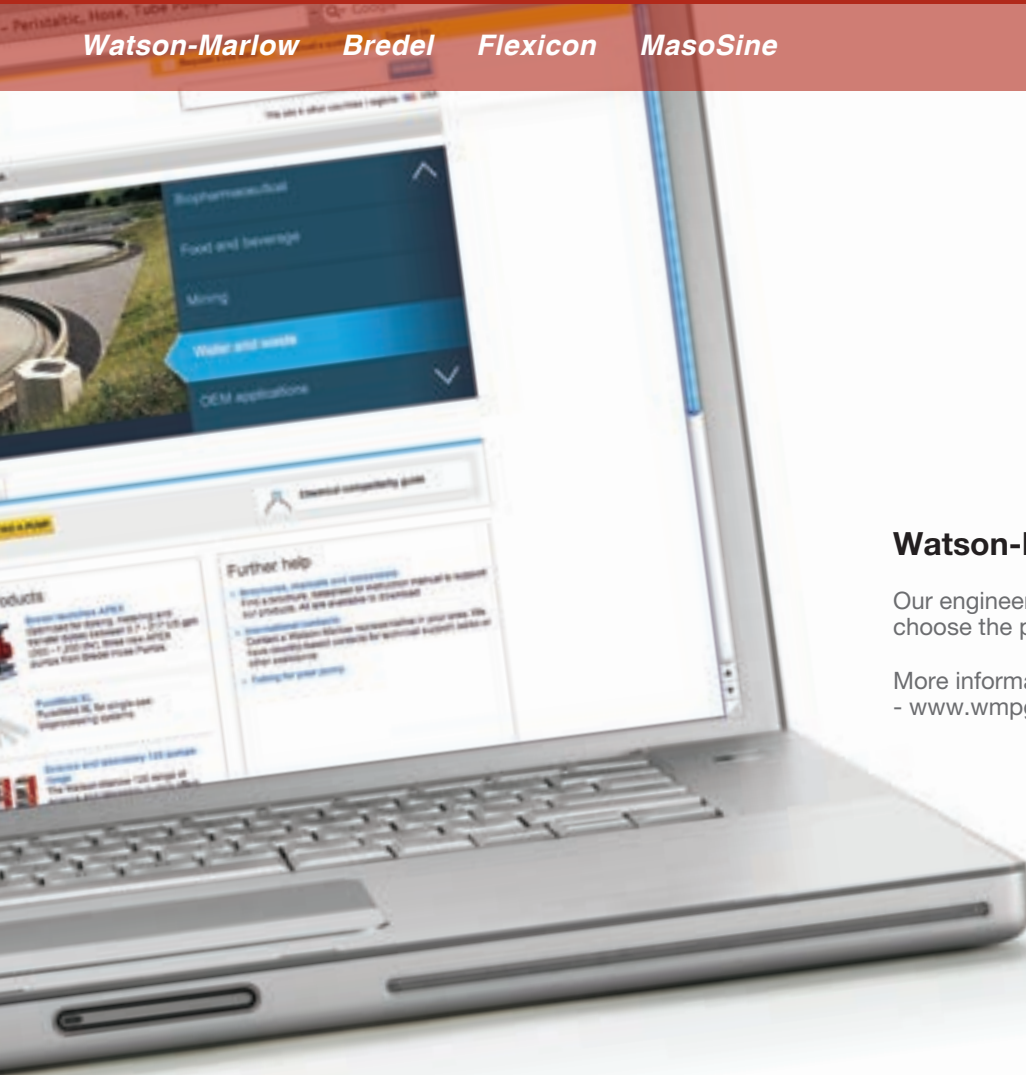

Watson-Marlow online

Our engineers around the world can help you choose the perfect pump and tubing for your needs.

More information? Our brochures are on our website - www.wmpg.com

Tel: +44 (0)1326 370370
info@wmpg.co.uk
www.wmpg.co.uk

Watson-Marlow Pumps Group
Falmouth, Cornwall TR11 4RU, UK

The information contained in this document is believed to be correct at the time of publication, but Watson-Marlow Bredel BV accepts no liability for any error it contains, and reserves the right to alter specifications without prior notice. All mentioned values in this document are values under controlled circumstances at our test bed. Actual flow rates achieved may vary because of changes in temperature, viscosity, inlet and discharge pressures and/or system configuration. APEX, DuCoNite®, Bioprene® and Bredel are registered trademarks.